



# COMPANY INTRODUCTION



With a vision of becoming the leading Industrial & Automation Valve manufacturing and supplying company Nu-tech Controls established in 1995. We would like to introduce our selves as one of the leading Industrial & Automation Valves like Ball Valve, Gate Valve, Globe Valve, Check Valve, Automatic Control Valves, Pressure Reducing Valves, Safety Relief Valves, Pressure Reducing Stations, Pneumatic Control Valves & High Pressure Valves manufacturer based in the city of Ahmedabad. Our products are precision made widely used in Oil, Gas, Petrochemicals, Power, Fertilizer & Allied Industry worldwide. We are in exports of our precise products around the globe and have a network and promoters with enthusiastic response and rapid market growth. Our installed testing facility is having the capacity of 50,000 PSI of hydraulic pressure, 10,000 PSI of Pneumatic Pressure and Helium & Cryogenic Testing upon requirements. Quality and tailor made valve is our strength.

## CHAIRMAN'S MESSAGE

To embark on a journey of success one needs the tools of preparedness, foresight and strategy. These lead to the path of growth and high quality operation. Team Nu-Tech continues to emerge as a leading brand in Industrial and Automation Valve Products. With Its unmatched quality, state-of-the-art technology and pool of talented people, the group sets its vision.

VIPUL SHAH (Chairman)

## PRODUCT RANGE

- Ball Valves (Metal to Metal/ Fire Safe/High & Low Pressure)
- Gate Valves
- Globe Valves
- Check Valves
- Butterfly Valves
- Strainer (Y Type, T Type & Bucket Type)
- Automatic Control Valves
- Pressure Regulating Valves
- Pressure Reducing Valves
- Pressure Reducing Stations
- Safety Relief Valve
- Chock Valves
- Control Valves
- Pressure Vessels & Equipments, Skids



## OUR ACHIEVEMENTS

- ISO 9001 : 2015 CERTIFIED
- API 6A, 602, 6D MONOGRAM
- IBR CERTIFIED
- FIRE SAFE TEST CERTIFIED

## QUALITY POLICY

We at Nu-Tech Controls are committed for manufacturing and supplying products that shall give excellent performance and deep satisfaction to our global customers. We strive to achieve growth and leading position in supplying consistent quality products to our valued customers. Complying to requirements and consistent improvement in effectiveness of quality management system of API SPEC Q1, ISO 9001, API SPEC. 6D, API STD. 602 and API SPEC. 6A & also creating an environment of teamwork and innovative approach.



- ✓ Continuously upgrade itself with innovations and convergence of new technologies.
- ✓ Meet the changing trends by creating value-for-money products.
- ✓ Add more and more smiles in the faces of thousand of satisfied customers.



### Setting The Course, Driven By The Values !!

Nu-Tech's auto control valve offers wide variety of water works designs, engineered to meet the entire scope of liquid utility system requirements. This valve series is applicable for controlling pressure, rate of flow, surge and pump control for both supply and distribution line.

Auto control valves are hydraulically operated; diaphragm operated for multi functional operation for variety of non abrasive and non corrosive fluids. These fully automatic valves can operate with pilot pressure, offline pressure or from independent power source.

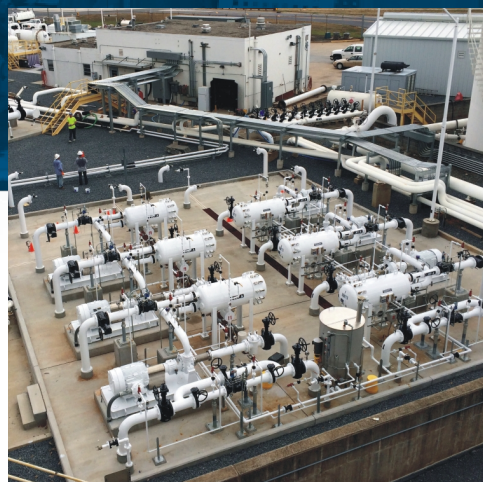

#### VALVE SPECIFICATION

<b>Sizes</b>	1/2" to 28"
<b>Pressure Class</b>	150#/300#/PN 6/PN 10/PN 16/ PN 25
<b>End Connection</b>	Threaded/Flanged
<b>Max. Working Pressure</b>	20 Bar
<b>Temperature Range</b>	-40 to 90° C
<b>Media</b>	Liquid

#### VALVE MATERIAL SPECIFICATION

<b>Body Material</b>	CI/CS/SS/Alloy Steel
<b>Seat Material</b>	SS/Alloy Steel
<b>Stem Material</b>	SS/Alloy Steel
<b>Soft Seat</b>	NITRILE/VITON/EPDM
<b>Spring Material</b>	SS 304/ SS 316

DEDICATED TO QUALITY



DEDICATED TO PERFORMANCE



DEDICATED TO RELIABILITY



## PRESSURE REDUCING VALVE

NU-TECH ACV Pressure Reducing Valves reduce high stream pressure to constant downstream pressure, outlet pressure across a broad range of flow.

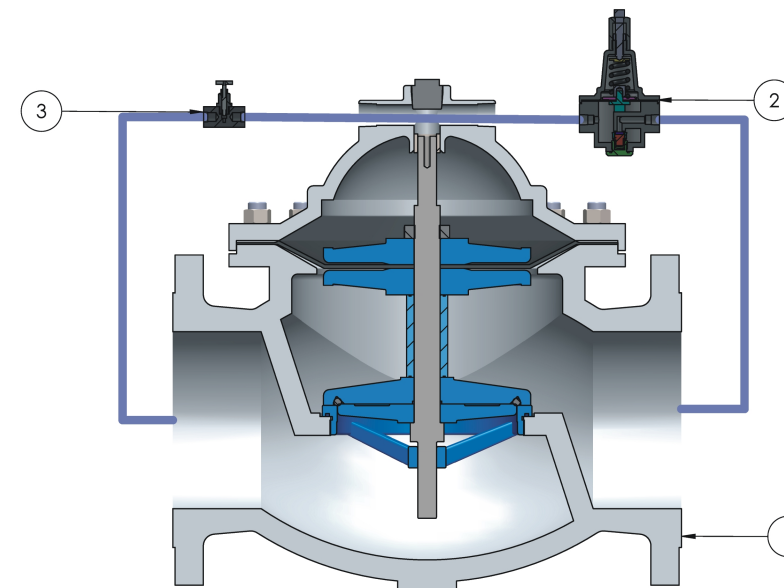

1. Main Valve 2. Pressure Reducing Pilot 3. Needle Valve

#### FEATURE

- Easily maintained without removal from the line.
- Replaceable seat ring.
- Heavy-duty, nylon-reinforced diaphragm.
- Operates automatically off line pressure.
- Valves are factory tested.
- Diaphragm assembly Guided top and bottom.

#### OPERATION

- Maintains a constant downstream pressure despite fluctuations in demand and inlet pressure
- Valves can be installed in series or parallel set ups for extended flow range or stage wise pressure reduction

#### COMBINE FEATURES

- Pressure reducing with hydraulic check
- Solenoid (on-off)
- Downstream surge protection
- Upstream pressure sustaining
- Pressure reducing with low flow control

#### PILOT VALVE

- Accurate sensing of outlet pressure.
- Simple, single adjustment.
- All parts replaceable while mounted on valve
- Rubber-to-metal seat for positive shut-off.
- Large area diaphragm for quick, precise throttling.

SIZE	1 1/4"	1 1/2"	2"	2 1/2"	3"	4"	6"	8"	10"	12"	14"	16"
<b>MAX. FLOW RATE (G.P.M.)*</b>	100	130	210	305	470	805	1815	3120	4905	7010	8508	11020

\* VELOCITY IN FT/SEC AND MTRS/SEC - 22FT, 6.7 MTRS

# PRESSURE RELIEF / SUSTAINING CONTROL



NU-TECH ACV Pressure Relief/Sustaining Valves operates when inlet pressure is above the set point, and throttle when pressure is below the field-adjustable set point. The valve will be in closed position if upstream pressure drops below the set point and will fully open when the upstream pressure exceeds the set point.

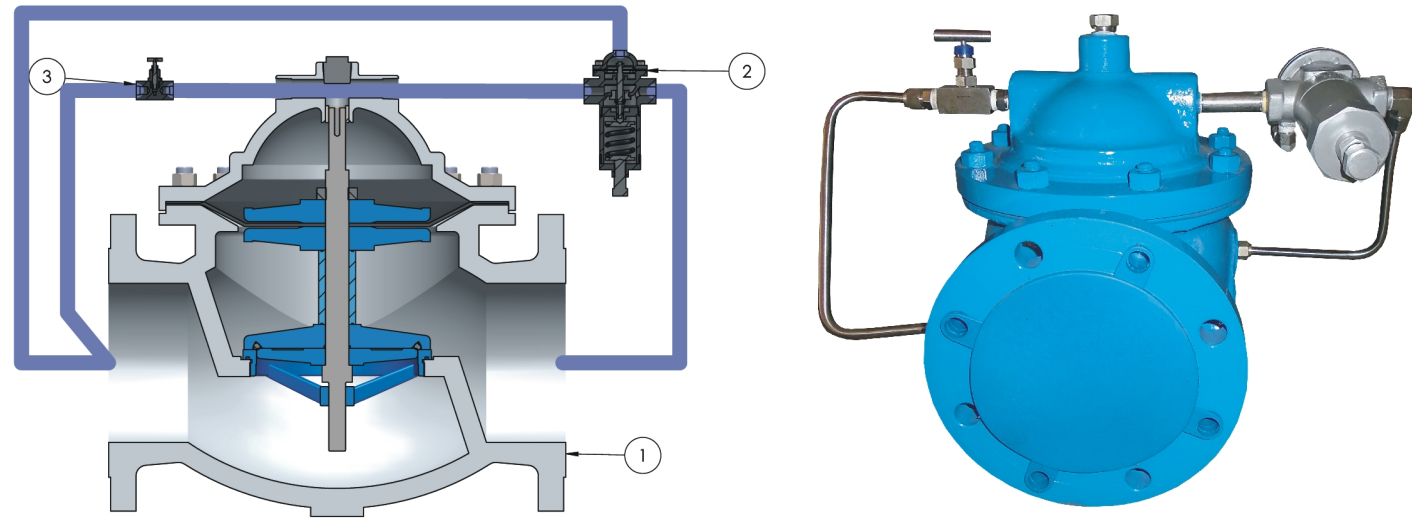

1. Main Valve 2. Pressure Relief Pilot 3. Needle Valve

## FEATURE

- Easily maintained without removal from the line.
- Replaceable seat ring.
- Heavy-duty, nylon-reinforced diaphragm.
- Operates automatically off line pressure.
- Valves are factory tested.
- Diaphragm assembly Guided top and bottom.

## COMBINE FEATURES

- Pressure sustaining with hydraulic check
- Pressure relief, sustaining or back pressure control valve
- Solenoid (on-off)
- Pressure relief and surge anticipator
- Pressure relief, sustaining & back pressure

SIZE	1 1/4"	1 1/2"	2"	2 1/2"	3"	4"	6"	8"	10"	12"	14"	16"
MAX. FLOW RATE (G.P.M.)*	100	130	211	308	468	807	1810	3112	4902	7005	8515	11010

\* BASED ON PIPELINE VELOCITY AT 22 FEET PER SECOND (6.7 METERS)

## OPERATION

- Closed under normal operating pressures.
- Valves opens when pressure rises to the set point
- Valves will close when system pressure drops below set point.

## PILOT VALVE

- Accurate sensing of outlet pressure.
- Simple, single adjustment.
- Visual indication of diaphragm condition.
- All parts replaceable while mounted on valve
- Rubber-to-metal seat for positive shut-off.
- Large area diaphragm for quick, precise throttling.

# SEPARATE OPENING CLOSING SPEED CHECK VALVE



NU-TECH ACV Non-Surge Check Valves are equipped with separate adjustable opening and closing speed controls to avoid pipeline surges.

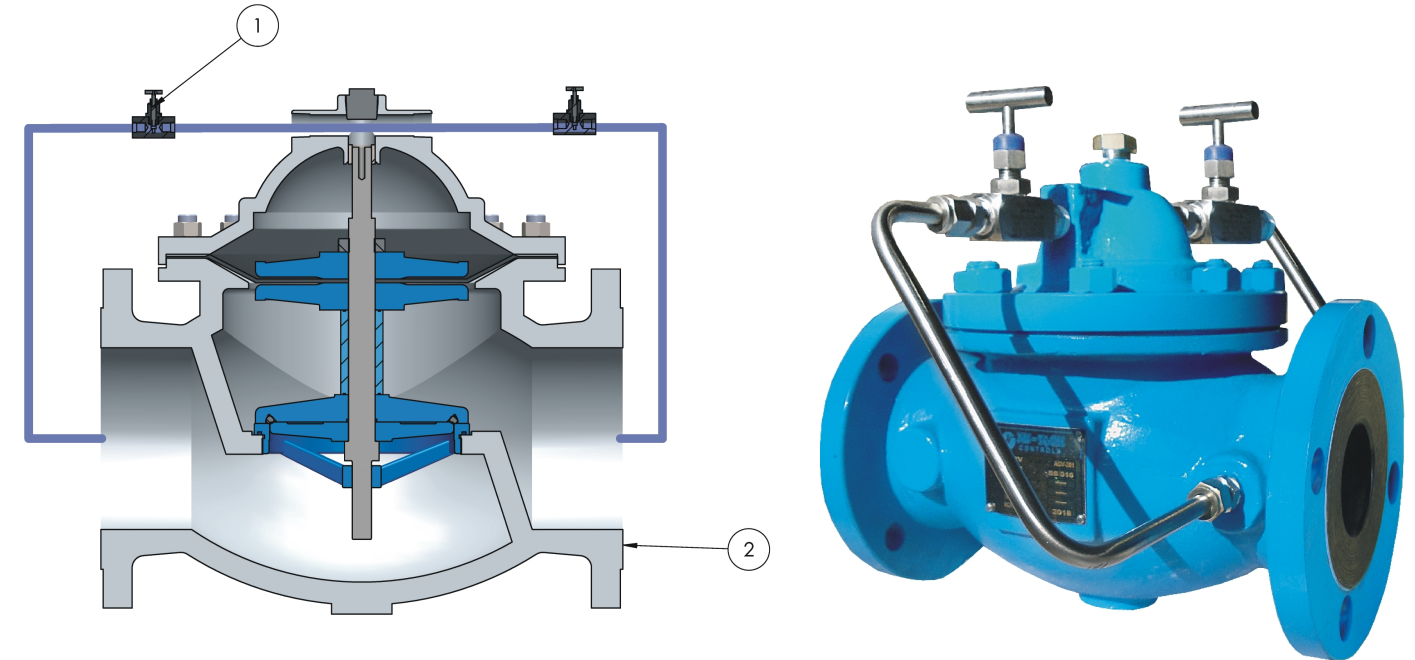

1. Needle Valve 2. Main Valve

## FEATURE

- Easily maintained without removal from the line.
- Replaceable seat ring.
- Diaphragm replaced without removing internal stem assembly.
- Heavy-duty, nylon-reinforced diaphragm.
- Operates automatically off line pressure.
- Valves are factory tested.
- Diaphragm assembly Guided top and bottom.
- Pump is protected from reverse flow.
- Maximum corrosion protection.
- Can be equipped with limit switches or a position indicator.

## COMBINE FEATURES

- No surge check valve
- Opening speed control only
- Closing speed control only

SIZE	1 1/4"	1 1/2"	2"	2 1/2"	3"	4"	6"	8"	10"	12"	14"	16"
MAX. FLOW RATE (G.P.M.)*	30	40	65	98	144	247	560	957	1465	2119	2608	3414

\* MAX. FLOW IS BASED ON PIPELINE VELOCITY OF 7 FEET (2.1 METERS) PER SECOND

# ALTITUDE CONTROL



The NU-TECH Altitude Control valve is designed to control the water level in tanks or elevated storage reservoirs without use of floats or sensors.

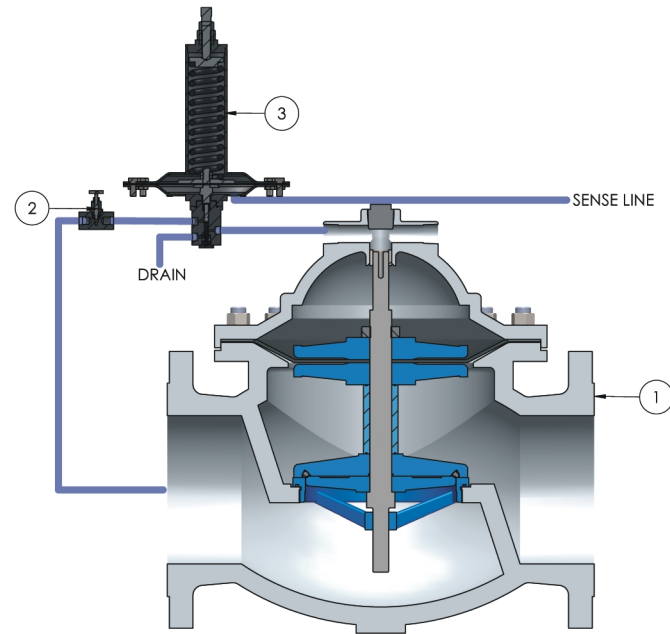

1. Main Valve 2. Needle Valve 3. Altitude Pilot-Level Control Pilot

## FEATURE

- Easily maintained without removal from the line.
- Replaceable seat ring.
- Heavy-duty, nylon-reinforced diaphragm.
- Operates automatically off line pressure.
- Valves are factory tested.
- Diaphragm assembly Guided top and bottom.
- Valves equipped with separate adjustable opening and closing speed controls

## COMBINE FEATURES

- One way flow with pressure sustaining.
- One way & two way flow with delay open for return flow.
- One way & two way flow with solenoid.

SIZE	1 1/4"	1 1/2"	2"	2 1/2"	3"	4"	6"	8"	10"	12"	14"	16"
MAX. FLOW RATE (G.P.M.)*	98	128	211	309	465	810	1815	3118	4911	7010	8508	11015

\* MAX. NORMAL FLOW BASED ON PIPELINE VELOCITY AT 22 FEET PER SECOND

## OPERATION

- One way valve: It is designed to open & allowing into tank & close drip tight when water level is achieved.
- Two way valve: it is designed to open & allowing into tank & close drip tight when water level is achieved. This valve also opens & allows return flow when inlet pressure is lower than tank head pressure.
- Monitors tank head pressure through a field-installed sensing line that opens for tank fill and closes at the desired level

## PILOT VALVE

- Accurate shut-off to within inches of set point.
- Automatic tank fill and shut-off without the use of floats or sensors.
- Minimum pressure loss.
- High level point adjustable with single screw.

# PUMP CONTROL/SOLENOID ON-OFF CONTROL VALVE



NU-TECH ACV Pump Control Valves are used to minimize surges commonly associated with the starting and stopping of pumps.

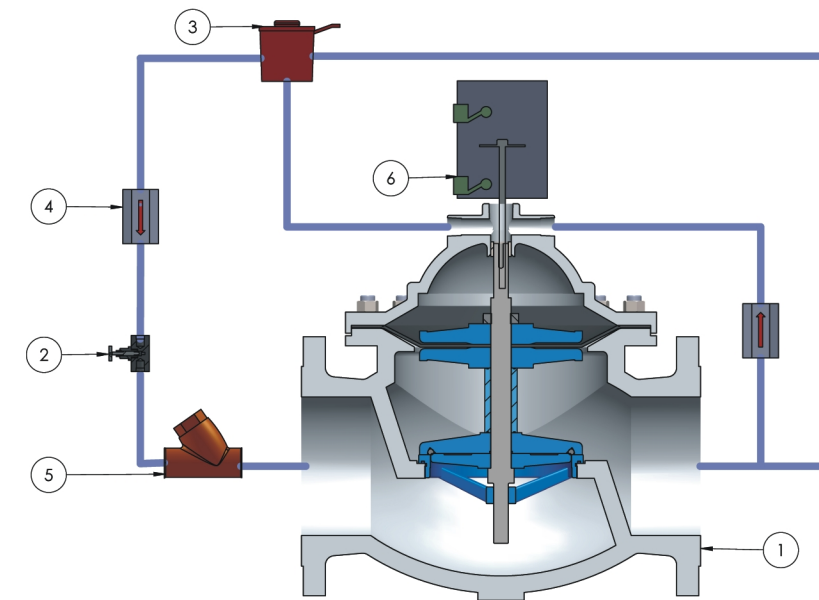

1. Main Valve 2. Needle Valve 3. Solenoid Valve 4. Check Valve 5. Strainer 6. Limit Switch

## FEATURE

- Easily maintained without removal from the line.
- Single chamber & double chamber.
- Replaceable seat ring.
- Heavy-duty, nylon-reinforced diaphragm.
- Operates automatically off line pressure.
- Valves are factory tested.
- Diaphragm assembly Guided top and bottom.
- Valves equipped with separate adjustable opening and closing speed controls.

## COMBINE FEATURES

- Check function.
- Pressure sustaining
- Pressure reducing.
- Rate of flow feature.

SIZE	1 1/4"	1 1/2"	2"	2 1/2"	3"	4"	6"	8"	10"	12"	14"	16"
MAX. FLOW RATE (G.P.M.)*	99	132	215	305	470	806	1805	3115	4910	7015	8514	11013

\* BASED ON PIPELINE VELOCITY AT 22 FEET PER SECOND (6.7 METERS PER SECOND)

# FLOAT CONTROL ACV



NU-TECH's float control ACV are designed to maintain a desired level in a tank or reservoir by opening for filling the tank when fluid is below the high level point and closing tightly when desired level is achieved.

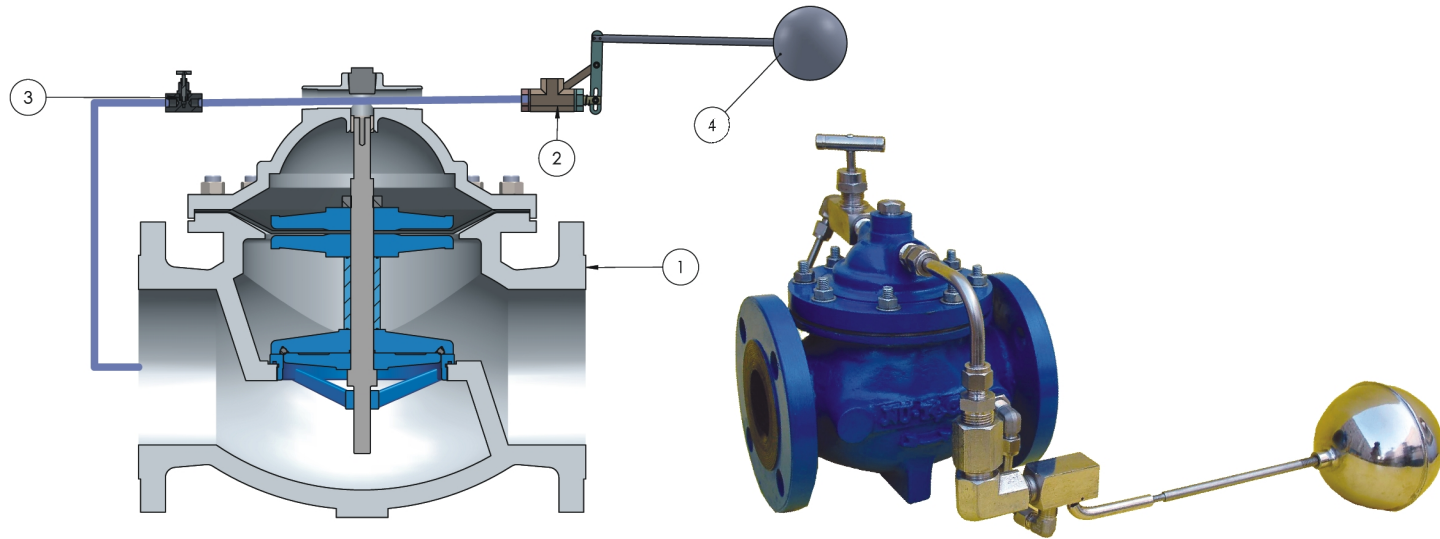

1. Main Valve 2. Float Control Pilot 3. Needle Valve 4. Float

## FEATURE

- Easily maintained without removal from the line.
- Replaceable seat ring.
- Heavy-duty, nylon-reinforced diaphragm.
- Operates automatically off line pressure.
- Valves are factory tested.
- Diaphragm assembly Guided top and bottom.

## COMBINE FEATURES

- Modulating for constant tank level.
- Modulating with pressure sustaining for constant tank level
- On-off for adjustable high and low levels.
- On-off with pressure sustaining features.
- Modulating with solenoid.

## OPERATION

- A single sense line connects the pilot to the ejector on the main valve.
- It is designed to maintained the liquid level in a reservoir.
- It sustain minimum upstream pressure during tank filling process.
- It is open on a lowering liquid level and closed upon a rising liquid level.
- On-off type valves controlled by float pilot equipped with adjustable high- and low-level stop collars allow for calculated level draw-down
- Modulating-type valves maintain constant water level proportional with tank draw

## PILOT VALVE

- Rotary float pilot.
- Design for modulation.
- Suitable for both water & fuel service.

SIZE	1 1/4"	1 1/2"	2"	2 1/2"	3"	4"	6"	8"	10"	12"	14"	16"
MAX. FLOW RATE (G.P.M.)*	98	134	205	314	462	810	1811	3115	4908	7014	8510	11015

\* MAX. NORMAL FLOW BASED ON PIPELINE VELOCITY AT 22 FEET PER SECOND

# DELUGE VALVE



Nutech ACV Deluge valve can be configured for automatically opens to admit water through the main line when the pneumatic/hydraulic or electric supply pressure is removed.

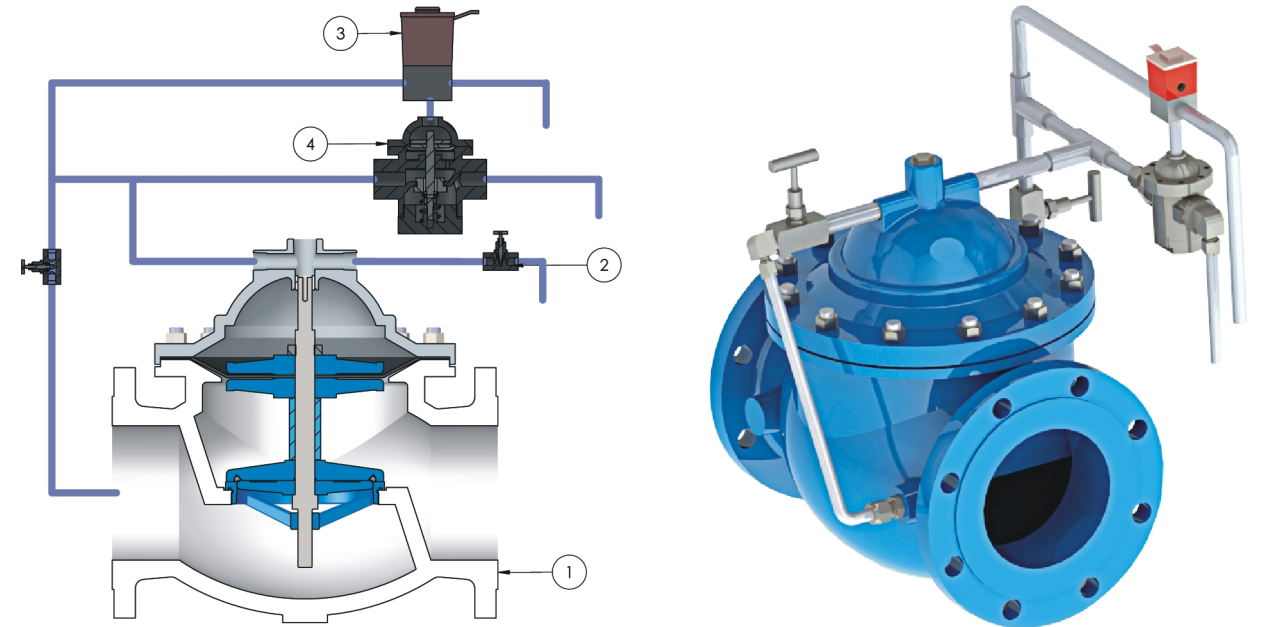

1. Main Valve 2. Needle Valve 3. Solenoid Valve 4. Deluge Pilot

## FEATURE

- Easily maintained without removal from the line.
- Replaceable seat ring.
- Heavy-duty, nylon-reinforced diaphragm.
- Operates automatically off line pressure.
- Valves are factory tested.
- Used in fire protection systems.
- Valve activated by level sensors, fills storage tank.
- Diaphragm assembly Guided top and bottom.

## COMBINE FEATURES

- Solenoid with hydraulic check.
- Electronic for electronic valve positioning.
- Valves can be equipped with limit switches or 4-20 mA position feedback device
- Hydraulic & Pneumatic operating option.

SIZE	1 1/4"	1 1/2"	2"	2 1/2"	3"	4"	6"	8"	10"	12"	14"	16"
MAX. FLOW RATE (G.P.M.)*	100	133	210	308	469	812	1805	3110	4900	7010	8515	11000

\* BASED ON PIPELINE VELOCITY AT 22 FEET PER SECOND (6.7 METERS PER SECOND)

# RATE OF FLOW CONTROL



NU-TECH ACV Rate-of-Flow Valves are designed to limit flow rate to an adjustable maximum.

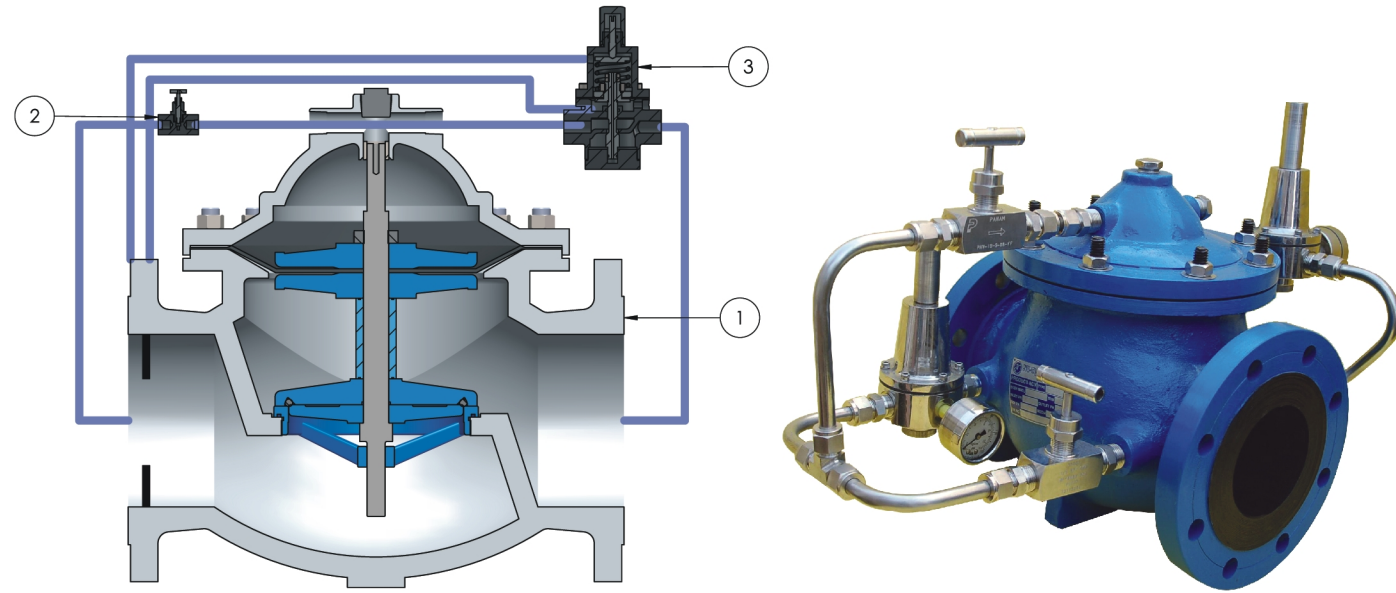

1. Main Valve 2. Needle Valve 3. Rate of Flow Control Pilot

## FEATURE

- Easily maintained without removal from the line.
- Replaceable seat ring.
- Heavy-duty, nylon-reinforced diaphragm.
- Operates automatically off line pressure.
- Used at water distribution system
- Used at filter backwash control.
- Valves are factory tested.
- Diaphragm assembly Guided top and bottom.

## COMBINE FEATURES

- Solenoid (On-Off)
- Pressure reducing
- Hydraulic check
- Pressure sustaining

## OPERATION

- It is designed to control or limit flow to a constant, predetermined rate regardless of fluctuation in upstream and downstream pressure.
- Differential pressure across the orifice plate is less than the pilot setting, the valve remains open.
- The pilot and main valve remain closed until manually reset.
- It protecting against a break in the downstream pipe.
- Senses differential pressure across a factory-calibrated orifice plate, then accurately throttles to maintain field-adjustable flow rate
- Orifice plate can be installed downstream or upstream, making it ideal for pressurized pipeline or open reservoir water-blending applications

## PILOT VALVE

- Hydraulically balanced design for accurate control.
- Large diaphragm area for sensing small changes in differential pressure.
- Specifically designed for rate of flow of control.
- Pilot is field adjustable.

SIZE	1 1/4"	1 1/2"	2"	2 1/2"	3"	4"	6"	8"	10"	12"	14"	16"
MAX. FLOW RATE (G.P.M.)*	55	80	128	185	277	489	1013	1905	2910	4211	5215	6808

\* BASED ON LINE VELOCITY OF APPROXIMATELY 15 FEET PER SECOND (4.57 METERS)

# ACV FLOW CHART



Designing automatic control valve is a critical balancing force on one hand you must confidence not only in the quality and performance of the valve, but also in the knowledge and hands-on expertise of the manufacturer. On the other hand, product reliability must be unquestioned, meeting the exact design parameters specified. Orders must be shipped as promised, keeping your job on track, and after the sale support is essential. You can count on Nu-Tech to deliver the highest quality automatic control valves available, and service second to none.

Designing automatic control valve is a critical balancing force on one hand you must confidence not only in the quality and performance of the valve, but also in the knowledge and hands-on expertise of the manufacturer. On the other hand, product reliability must be unquestioned, meeting the exact design parameters specified. Orders must be shipped as promised, keeping your job on track, and after the sale support is essential. You can count on Nu-Tech to deliver the highest quality automatic control valves available, and service second to none.

Our premises trained engineers offer detailed specification assistance, analyzing system conditions to recommend the right valve for your application. System, material and application considerations are reviewed, so the right control valve is selected for your project. You can be confident that Nu-Tech and our local representatives are ready and able to assist your design team.

With a long service in commercial plumbing, municipal waterworks, fire protection, irrigation, aviation fueling, marine, theme park, decorative fountain, light industrial and reclaimed water markets. Nu-Tech has the expertise and products to meet your needs. Nu-Tech has kept pace with changing market, developing and delivering quality automatic control valves at affordable prices.

Our fusion bonded, epoxy coated, ductile iron automatic control/valves offer long life and minimal maintenance. And for harsh applications and environments, our fabricated stainless steel valves provide a cost effective solution. Whether your application requires pressure, level, pump or flow control, Nu-Tech is your best choice for selection, sales and service.

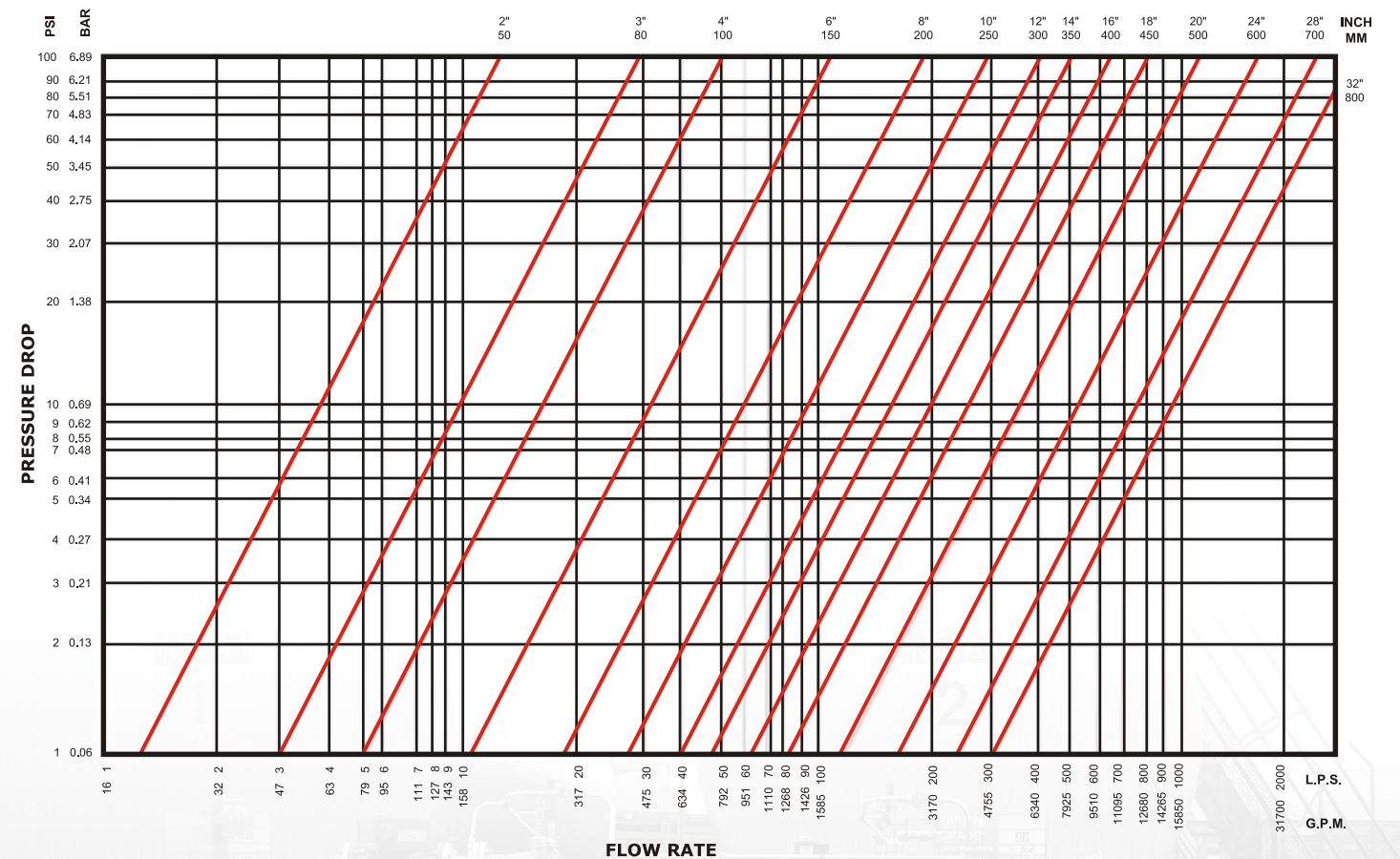

The Valve Flow Rate May Be Verified From The Equation :

$$Q = C_v \sqrt{\Delta p}$$

Where... Q = Flow rate, gallons per minute  
 Tank Fill-(System pressure minus tank head in psi)  
 Flow out of tank-(Tank head in psi minus system pressure)

# SLUICE GATE VALVE



## DESIGN FEATURE

- Bolted Bonnet • Inside screw • Non-rising stem
- Variety of materials • Rigid design • Higher Efficiency
- Low friction & Smooth operations • Hand wheel operated
- Resilient wedge • Bubble tight shut-off. • Renewable seat
- Solid wedge • Long service life

## APPLICATION

- Water supply corporations
- Municipal corporation
- Various industrial applications
- Thermal power Corporation
- Nuclear power corporation

## MODES OF OPERATION

- Hand wheel operated
- Gear operated
- Electric actuator operated
- Pneumatically actuator operated
- Pneumatically operated with electro pneumatic positioned.

## SPECIFICATION

- Design standard IS 14846 /BS 5163 / also available with DIN & AWWA standards as per customer's requirement
- Flange drilling as per BS EN 1092-2 / BS 4772 / IS 1538 / ANSI B16.1 / BS 10
- Face to Face dimension ANSI B16.10 / BS 5163 / DIN 3202 / ISO 5752
- Testing for zero leakage API 598/ AWWA C501

## DESIGN

Nu-Tech Sluice gate valves are designed and manufactured to provide maximum service life and dependability. All Sluice gate valves are full ported and meet the design requirements of IS 14846 & other standards as per customer requirements. Valves are available in complete range of body/bonnet & trim materials.

## RANGE OF MATERIALS

Standard body/bonnet materials include different grades of cast iron / Ductile iron. For special applications they can be supplied in the other grades of alloys. There is a full range of trim materials to match any service optional packing & gasket materials are available for a full range of service conditions.

## OPERATION

Large hand wheels for easy operations. Also available with gearing motor actuators, pneumatic or hydraulic actuators for more difficult services.

## WEDGE

The Wedge is a seal element and heart of gate valve. Guides in the wedge and on the valve body ensure a uniform closure regardless of high pressure. Safe operation is ensure, as the guides prevent overloading of the stem.

## AVAILABLE MODIFICATION

- Trim changes • Hand wheel extension • Valve locking device • Indicator • Drain plug • Limit switches
- End connections modifications • Customer specified coating • Packaging

# AIR VALVE



## SPECIFICATION

- Manufacturing Standard ANSI / AWWA C512
- Flange Standard EN1092-2
- Dimension AWWA M51
- Testing Standard DIN 30677 / AWWA C512
- NSF 61/372- For Drinking Water System

## TYPES

- Air release valves
- Air/vacuum valves
- Combination Air valves
- Cylinder float type
- Dual purpose ball float type
- Automatic float type
- Kinetic ball type

## FUNCTIONS

- Air release valves: Automatically releases air while the pipeline operates under pressure.
- Air/vacuum valve: Exhaust large quantities of air during pipeline filling & admit large amounts of air when internal pressure drops below atmospheric.
- Combination Air valves: perform both as air release and air/vacuum valves.

## AVAILABLE MODIFICATION FOR NU-TECH VALVES

- Trim changes • End connection modifications • Customer specified coatings • Operator mounting • Packaging

## DESIGN FEATURE

- Guided floats.
- Single chamber
- Compact design.
- Self cleaning float guides.
- Corrosion protection.
- Resilient seats.
- Full size flow area.
- Stainless steel body.
- Non-clog design eliminates back washing.
- Suitable for use in water treatment, water distribution, in dams, power plants & industry.
- Combination of air valve & vacuum valve.
- Zero maintenance.
- Temper proof design of air vent.
- Compact and light weight
- Simple lever or compound lever

## DESIGN

NU-TECH air valves are designed and manufactured to provide maximum service life & dependability. All air valves are full ported and meet the design requirements of American National Standards institute standard C512. Valves are available in complete range of body and trim materials.

# BUTTERFLY VALVE



## DESIGN FEATURE

- Unique stem retention system to provide blow-out proof stem and easy assembly and disassembly of valve.
- Heavy duty one piece wafer and lugged wafer body designed to withstand specified pressures.
- Heavy duty bearing absorbs the forces acting on the stem/disc assembly due to line pressure.
- Longer life
- Tight Sealing and Consistent low torque.
- Assured Shaft Sealing.
- Actuator mounting Platform
- Lower resistance to flow
- Ease of installation
- Reliable drive
- Low pressure drop
- More compact.
- Required less space & lighter.
- Electro pneumatically operated
- Easy maintain.
- Low Operating torque.
- Low friction and wear.
- Renewable cartridge seat

## DESIGN

NU-TECH Butterfly valves are designed and manufactured to provide maximum service life & dependability. All butterfly valves are meets the design requirements of American Petroleum institute standard 609. Valves are available with complete body and trim materials.

## APPLICATION

- Petroleum industry
- Gas industry
- Food industry
- Shipping industry
- Water treatment plants
- Medicine industry etc.

## SPECIFICATION

- Design and manufacturing : API 609/MSS SP-67
- Connection Dimension Conforms with : ASME B16.5/ASME B16.47
- End To End Dimension : API 609/MSS SP-67/ISO 5752
- Inspection & Testing Standard : ISO 5208/API 598

## DESIGN TYPES

- Centric butterfly valves.
- Double eccentric butterfly valves.
- Triple offset butterfly valves.
- Double eccentric disc and stem.
- Spherical sealing structure.

## AVAILABLE MODIFICATION FOR NU-TECH VALVES

- Trim changes
- Customer specified coatings
- Operator mounting
- Packaging

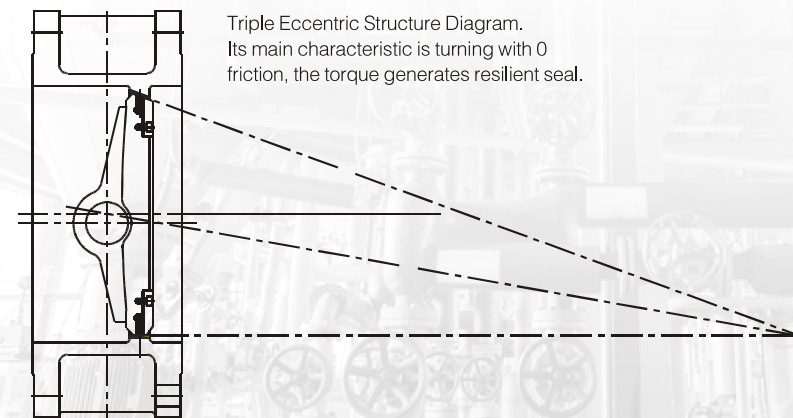

Triple Eccentric Structure Diagram.  
Its main characteristic is turning with 0 friction, the torque generates resilient seal.

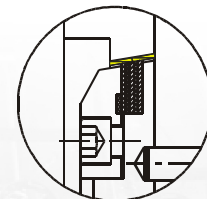

Multiple arrangement  
metal hard sealed structure

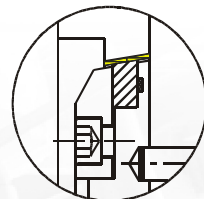

metal resilient sealed structure

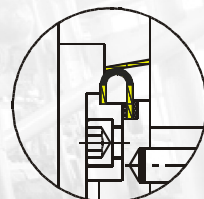

U metal sealed structure

# BUTTERFLY VALVE

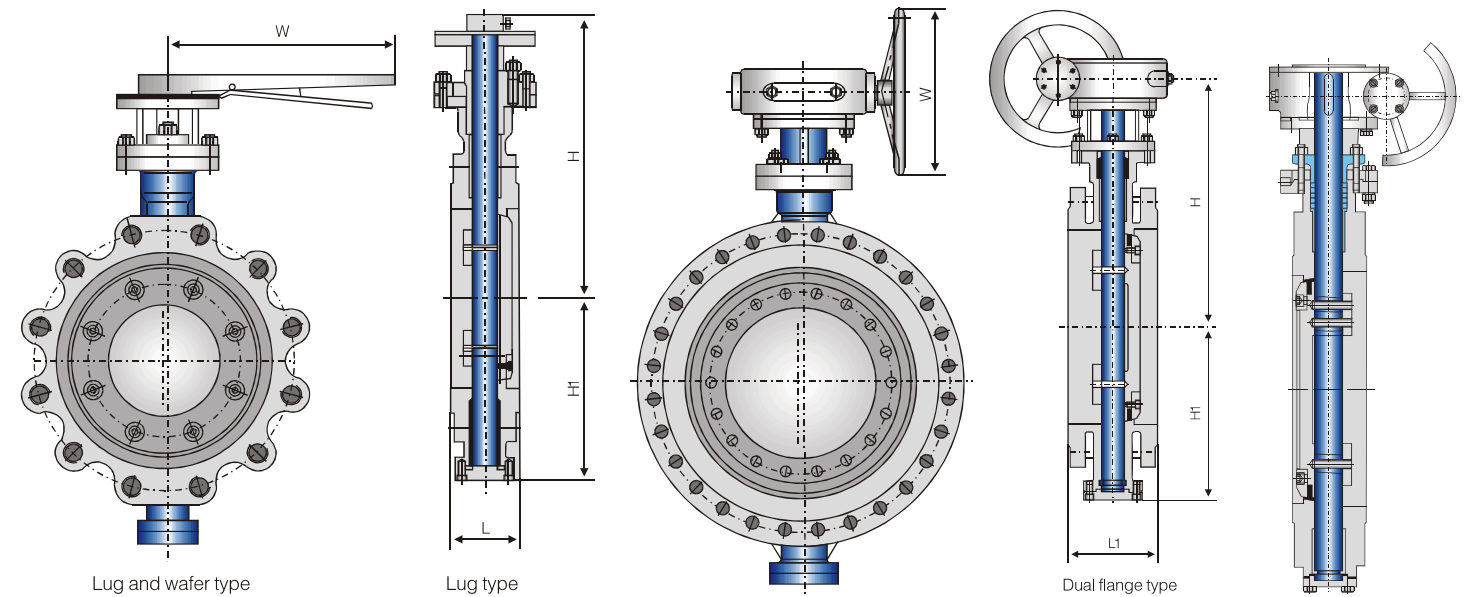

## DIMENSIONAL DATA'S OF ANSI CLASS 150 LB

NPS	2	3	4	6	8	10	12	14	16	18	20	24	30	36	42	48
DN	50	80	100	150	200	250	300	-	400	450	500	600	750	900	1050	1200
L mm	43	48	54	57	64	71	81	92	102	114	127	154	165	200	251	276
L1 mm	108	114	127	140	152	165	178	190	216	222	229	267	318	330	410	470
H1 mm	112	126	146	170	218	245	290	316	352	386	415	482	622	673	755	866
H mm	225	255	285	332	386	427	498	510	450	585	642	693	868	1000	1058	1278
W mm	220	270	270	360	300	300	500	500	600	600	600	600	600	700	700	700
MT (Wafer) kg	10	12	16	25	36	60	80	120	160	200	270	420	700	1050	1500	1845
T Nm	55	226	325	615	902	1278	2628	3276	4128	5511	7190	7814	16450	23501	31963	47000

## DIMENSIONAL DATA'S OF ANSI CLASS 300 LB

NPS	-	3	4	6	8	10	12	14	16	18	20	24	30	36	42	48
DN	50	80	100	150	200	250	300	-	400	450	500	600	750	900	1050	1200
L mm	-	48	54	59	73	83	92	117	133	149	159	181	-	-	-	-
L1 mm	-	114	127	140	152	165	178	190	216	222	229	267	318	330	410	470
H1 mm	-	130	150	185	236	273	313	338	392	420	465	532	642	703	785	906
H mm	-	265	290	355	418	465	498	547	582	651	704	780	908	1108	1258	1478
W mm	-	270	270	300	500	500	600	600	600	600	600	600	700	700	700	1000
MT (Wafer) kg	-	15	19	35	42	68	88	144	185	230	330	460	1280	2150	3150	4885
T Nm	3	352	514	1073	1954	2453	3260	5405	8152	10223	13469	22827	39726	63452	85326	126742

## DIMENSIONAL DATA'S OF ANSI CLASS 600 LB

NPS	3	4	6	8	10	12	14	16	18	20	24
DN	80	100	150	200	250	300	350	400	450	500	600
L mm	54	64	78	102	117	140	155	178	200	216	232
L1 mm	180	190	210	230	250	270	290	310	330	350	390
H1 mm	152	193	248	295	342	378	412	450	512	563	622
H mm	305	338	416	490	580	690	715	823	897	1094	1186
W mm	270	360	500	600	600	600	600	600	600	700	700
MT (Wafer) kg	38	58	120	154	297	398	535	780	898	1266	1622
T Nm	575	1043	3673	4520	7061	14236	16947	20473	25218	31861	46095

# DUAL PLATE CHECK VALVE



## SPECIFICATIONS

- Steel Check Valves API 594/API 6D
- Steel Check Valves ISO 14313
- Steel Valves ASME B16.34
- Face To Face ASME B16.10
- End Flanges ASME B16.5
- Butt Welding Ends ASME B16.25
- Inspection and Test API 598/API 6D

## DESIGN FEATURES

- One Piece Body
- Renewable Split Disc
- Horizontal or Vertical Service
- Wafer Ends
- Available With Flanged Ends

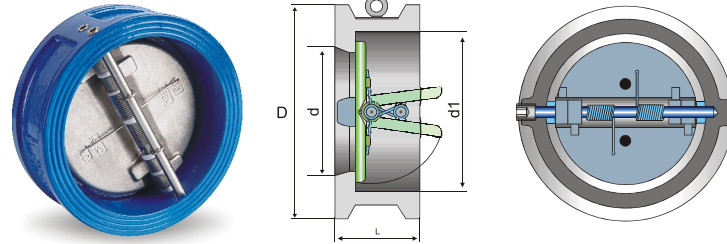

DIMENSIONAL DATA'S OF ANSI CLASS 150 LB														
NPS	2	2 1/2	3	4	6	8	10	12	14	16	18	20	24	in
DN	50	65	80	100	150	200	250	300	350	400	450	500	600	mm
L (RF/BW)	2.38	2.62	2.88	2.88	3.88	5.00	5.75	7.12	7.25	7.50	8.00	8.62	8.75	in
	60	67	73	73	98	127	146	181	184	191	203	219	222	mm
D	4.00	4.88	5.38	6.75	8.62	10.88	13.25	16.00	17.62	20.12	21.50	23.75	28.12	in
	103	122	135	173	220	277	337	407	488	512	547	604	715	mm
d	2.00	2.50	3.25	4.00	6.00	8.00	10.00	12.00	13.75	15.75	17.75	19.75	23.62	in
	51	65	80	102	152	203	254	305	350	400	450	500	600	mm
D1	2.25	2.88	3.50	4.25	6.25	8.25	10.50	12.12	14.00	16.00	18.00	19.88	23.75	in
	56	73	88	108	160	210	266	310	355	405	455	505	605	mm
Wt	2	3	4	6	13	25	39	54	80	117	138	163	331	kg.

DIMENSIONAL DATA'S OF ANSI CLASS 300 LB														
NPS	2	2 1/2	3	4	6	8	10	12	14	16	18	20	24	in
DN	50	65	80	100	150	200	250	300	350	400	450	500	600	mm
L (RF/BW)	2.38	2.62	2.88	2.88	3.88	5.00	5.75	7.12	8.75	9.12	10.38	11.50	12.50	in
	60	67	73	73	98	127	146	181	222	232	264	292	318	mm
D	4.25	5.00	5.75	7.00	9.88	12.00	14.12	16.50	19.00	21.12	30.38	25.62	30.38	in
	110	128	147	179	249	305	359	420	483	537	594	652	772	mm
d	2.00	2.50	3.00	4.00	6.00	8.00	10.00	12.00	14.00	16.00	18.00	20.00	24.00	in
	51	65	80	102	152	203	254	305	350	400	450	500	600	mm
D1	2.25	2.88	3.50	4.25	6.38	8.25	10.50	12.25	14.00	16.00	18.00	20.00	24.00	in
	58	73	88	108	160	210	266	310	355	405	455	505	608	mm
Wt	3	4	6	8	18	31	51	77	117	190	200	265	410	kg.

DIMENSIONAL DATA'S OF ANSI CLASS 600 LB													
NPS	2	2 1/2	3	4	6	8	10	12	14	16	in		
DN	50	65	80	100	150	200	250	300	350	400	mm		
L (RF/BW)	2.38	2.62	2.88	3.12	5.38	6.50	8.38	9.00	10.75	12.00	in		
	60	67	73	79	137	165	213	229	273	305	mm		
D	4.38	5.00	5.75	7.50	10.38	12.50	15.62	17.88	19.25	22.12	in		
	110	128	147	191	264	318	398	455	490	562	mm		
d	2.00	2.50	3.00	4.00	6.00	7.88	9.88	12.00	13.25	15.25	in		
	51	65	80	102	152	200	250	305	337	387	mm		
D1	2.25	2.88	3.50	4.25	6.38	8.38	10.50	12.25	14.00	157.75	in		
	58	73	88	108	162	212	266	312	355	405	mm		
Wt	4	5	8	11	26	55	95	140	223	360	kg.		

DIMENSIONAL DATA'S OF ANSI CLASS 900 LB													
NPS	2	2 1/2	3	4	6	8	10	12	14	16	in		
DN	50	65	80	100	150	200	250	300	350	400	mm		
L (RF/BW)	2.75	3.25	3.25	4.00	6.25	8.12	9.50	11.50	--	--	in		
	70	83	83	102	159	206	241	292	--	--	mm		
D	5.50	6.38	6.50	8.00	11.25	14.00	17.00	19.50	--	--	in		
	140	162	165	204	286	356	432	495	--	--	mm		
d	2.00	2.50	3.00	4.00	6.00	7.88	9.88	12.00	--	--	in		
	51	62	80	102	152	200	250	305	--	--	mm		
D1	2.25	2.88	3.50	4.25	6.38	8.38	10.50	12.25	--	--	in		
	58	73	88	108	162	212	266	312	--	--	mm		
Wt	8	11	14	20	42	84	145	220	--	--	kg.		

ph: 91 79 223122 2213312  
 Email: sales@nutechvalves.com / sales@nutechcontrols.com  
 Web: www.nutechvalves.com / www.nutechcontrols.com

# OTHER PRODUCT RANGE

