



AN ISO 9001 : 2015 CERTIFIED

# ENGINEERING THE QUALITY FOR YOUR SUCCESS

INDUSTRIAL, AUTOMATION VALVES AND HIGH PRESSURE SOLUTIONS





✓ ISO 9001:2008 Certified ✓ API 6A, 602, 6D Monogram & IBR Certified ✓ State of the art Infrastructure & Technology

## AUTOMATION VALVES

- › Automatic Control Valves
- › Pressure Regulating Valves
- › Pressure Reducing Valves
- › Pressure Reducing Stations
- › Safety Relief Valve
- › Chock Valves
- › Control Valves

## INDUSTRIAL VALVES

- › Ball Valves
- › (Metal to Metal / Fire Safe / High & Low Pressure)
- › Gate Valves
- › Globe Valves
- › Check Valves
- › Butterfly Valves
- › Strainer (Y Type, T Type & Bucket Type)

## PRESSURE VESSELS AND EQUIPMENTS, SKIDS

## INFRASTRUCTURE & TESTING FACILITY



## ABOUT NU-TECH GROUP

With a vision of becoming the leading Industrial & Automation Valve manufacturing and supplying company Nu-tech Controls established in 1995. We would like to introduce our selves as one of the leading Industrial & Automation Valves like **Ball Valve, Gate Valve, Globe Valve, Check Valve, Automatic Control Valves, Pressure Reducing Valves, Safety Relief Valves, Pressure Reducing Stations, Pneumatic Control Valves & High Pressure Valves** manufacturer based in the city of Ahmedabad.

Our products are precision made widely used in Oil, Gas, Petrochemicals, Power, Fertiliser & Allied Industry worldwide. We are in exports of our precise products around the globe and have a network and promoters with enthusiastic response and rapid market growth.

Our installed testing facility is having the capacity of 50,000 PSI of hydraulic pressure and 10,000 PSI of pneumatic pressure. Quality and tailor made valve is our strength.



## Model 500 (Compact Performance)

- Built in conformance to ASME Code/API for Air, Gas, Steam and Liquid Service.
- Pressure range up to 3000 psig.
- Material - C.S. / CF8 / CF8M / Alloy Steel flat seats for easy maintenance.

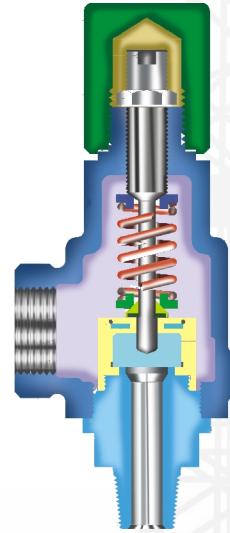

## Model H500 (High Performance)

- Built in conformance to ASME Code/API for Air, Gas, Steam and Liquid Service.
- Pressure range up to 10000 psig.
- Material - C.S. / CF8 / CF8M / Alloy Steel flat seats for easy maintenance.

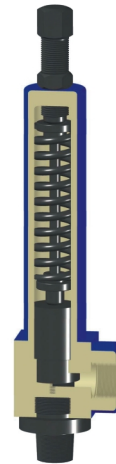

## Model SRV Open Bonnet 0-501

- Spring loaded safety relief valve.
- Open bonnet with cap & lever.
- Close bonnet with lever
- Metal seat
- Soft seat with PTFE & Viton
- Material - C.S. / CF8 / CF8M / Alloy Steel

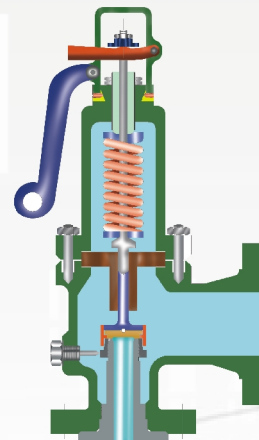

## Model Safety Relief Valve C 501

- Spring loaded safety relief valve.
- Open bonnet with cap & lever.
- Close bonnet with lever
- Metal seat
- Soft seat with PTFE & Viton
- Material - C.I / C.S. / CF8 / CF8M / Alloy Steel
- Pressure range up to 6500 PSIG.

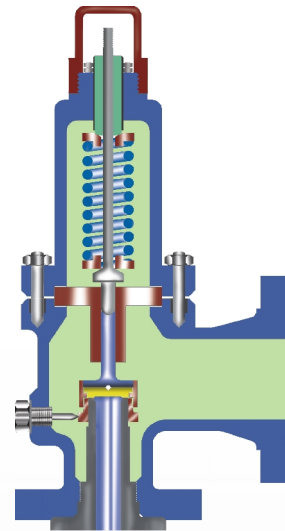

## Model PSRV 201

- The PSRV 201 series pilot operated valves are built in conformance to section VIII of the ASME boiler & pressure vessel code for Air, Gas, Vapor & Liquid Service.
- Material - C.I / C.S. / CF8 / CF8M / Alloy Steel
- Pressure range up to 6500 PSIG.

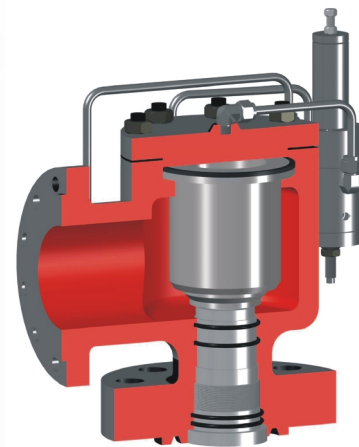

## Model PSRV 810

- Preliminary design for protecting low pressure storage vessels and tanks as well as low pressure piping system.
- Pressure range up to 20 PSIG.

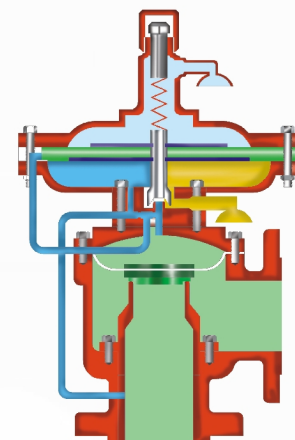

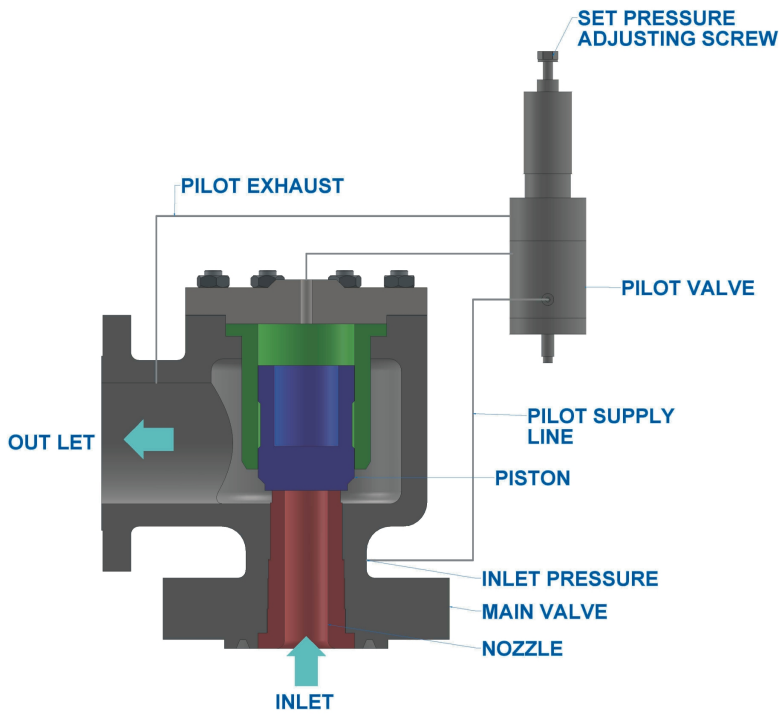

- ▶ Nu-tech Pilot Operated Safety Valve model PSV-201 and model-810.
- ▶ The PSV-201 series pilot operated valves are built in conformance to section VIII of the ASME boiler and pressure vessel code for Air, Gas, Vapor & Liquid service.
- ▶ The series 810 product is a very wide range of both pressure and pressure relief valves.
- ▶ Preliminary designed for protecting low pressure storage vessels and tanks, as well as low pressure piping joints.
- ▶ API 526 design ensuring standard valves sizes, dimensions and capacities for easy exchangeability in plants designed according to API standards.
- ▶ API 526 product range with valve sizes from 1\* to 8\* orifice D to T and pressure rating up to class 600.
- ▶ Additional extra orifices allowing to use a smaller valve size for a given orifice letter or capacity.
- ▶ Flange connections according to ASME, which guarantee worldwide suitability.

## Features

- Are used for application where the certified discharge capacity needs to be reached quickly.
- Are used for gas applications only.
- Have an adjustable blowdown of 2-7% of set pressure conforming to ASME which can be adjusted beyond API standards up to 15%.

## DIMENSIONAL DETAIL - PILOT OPERATED SAFETY RELIEF VALVE

ORIFICE TYPE	SIZE	CLASS	ORIFICE DIAMETER (D)	ORIFICE AREA (A)	CENTER TO BOTTOM (C/B)	CENTER TO FACE (C/F)	HEIGHT (H)
D	1 x 2	150x150	11	95	105	114	330
	1 - 1/2 x 2	150x150	11	95	124	121	359
	1 x 2	300x150	11	95	111	114	336
	1 - 1/2 x 2	300x150	11	95	124	121	359
	1 x 2	600x150	11	95	111	114	336
1 x 1/2 x 2	600x150	11	95	124	121	359	
E	1 x 2	150x150	14.7	169.7	105	114	330
	1 - 1/2 x 2	150x150	14.7	169.7	124	121	359
	1 x 2	300x150	14.7	169.7	111	114	336
	1 - 1/2 x 2	300x150	14.7	169.7	124	121	359
	1 x 2	600x150	14.7	169.7	111	114	336
1 x 1/2 x 2	600x150	14.7	169.7	124	121	359	
F	1 x 2	150x150	18.4	265.9	105	114	330
	1 - 1/2 x 2	150x150	18.4	265.9	124	121	359
	1 x 2	300x150	18.4	265.9	111	114	336
	1 - 1/2 x 2	300x150	18.4	265.9	124	121	359
	1 x 2	600x150	18.4	265.9	111	114	336
1 x 1/2 x 2	600x150	18.4	265.9	124	121	359	
G	1 x 2	150x150	23	415.5	105	114	330
	1 - 1/2 x 3	150x150	23.6	437.4	130	124	370
	2 x 3	150x150	23.6	437.4	137	124	386
	1 x 2	300x150	23	415.5	111	114	336
	1-1/2x3	300x150	23.6	437.4	130	124	370
	2x3	300x150	23.6	437.4	137	124	386
	1x2	600x150	23	415.5	111	114	336
	1-1/2x3	600x150	23.6	437.4	130	124	370
	2x3	600x150	23.6	437.4	137	124	386
	2x3	900x300	23.6	437.4	172	167	410
	2x3	1500x300	23.6	437.4	172	167	410
2x3	2500x300	23.6	437.4	172	178	426	
H	1-1/2x2	150x150	29	660.5	124	121	359
	1-1/2x3	150x150	29.4	678.9	130	124	370
	2x3	150x150	29.4	678.9	137	124	386
	1-1/2x3	300x150	29	660.5	124	121	359
	1-1/2x3	300x150	29.4	678.9	130	124	370
	2x3	300x150	29.4	678.9	137	124	386
	1-1/2x2	600x150	29	660.5	124	121	359
	1-1/2x3	600x150	29.4	678.9	130	124	370
	2x3	600x150	29.4	678.9	137	124	386
J	1-1/1x3	150x150	35.7	1001	130	124	370
	2x3	150x150	38	1134.1	137	124	386
	1-1/2x3	300x150	35.7	1001	130	124	370
	2x3	300x150	38	1134.1	137	124	386
	1-1/2x3	600x150	35.7	1001	130	124	370
	2x3	600x150	38	1134.1	137	124	386
	3x4	150x150	38	1134.1	156	162	428
	3x4	300x150	38	1134.1	156	162	428
	3x4	600x150	38	1134.1	162	162	434
K	3x4	150x150	45	1590.4	156	162	428
	3x4	300x150	45	1590.4	156	162	428
	3x4	600x150	45	1590.4	162	162	434
	3x4	150x150	56	2463	156	162	428
L	4x6	150x150	56	2463	197	210	481
	3x4	300x150	56	2463	156	162	428
	4x6	300x150	56	2463	197	210	481
	3x4	600x150	56	2463	162	162	434
	4x6	600x150	56	2463	197	210	481
	4x6	900x300	56	2463	234	250	559
	4x6	1500x300	56	2463	234	250	559
	4x6	2500x300	56	2463	234	250	559
	4x6	150x150	63	3117.3	197	210	481
M	4x6	300x150	63	3117.3	197	210	481
	4x6	600x150	63	3117.3	197	210	481
	3x4	900x300	63	3117.3	181	191	486
	3x4	1500x300	63	3117.3	181	191	486
	3x4	2500x300	63	3117.3	181	191	486
	4x6	150x150	69	3739.3	197	210	481
N	4x6	300x150	69	3739.3	197	210	481
	4x6	600x150	69	3739.3	197	210	481
	4x6	150x150	83	5410.6	197	210	481
P	4x6	300x150	83	5410.6	197	210	481
	4x6	600x150	83	5410.6	197	210	481
	4x6	150x150	83	5410.6	197	210	481
Q	6x8	150x150	110	9503.3	240	241	580
	6x8	300x150	110	9503.3	240	241	580
	6x8	600x150	110	9503.3	246	241	586
R	6x8	150x150	133	13892.9	240	241	580
	6x8	300x150	133	13892.9	240	241	580
	6x8	600x150	133	13892.9	246	241	586
T	8x10	150x150	168	22167	276	279	683
	8x10	300x150	168	22167	276	279	683
	8x10	600x150	168	22167	297	279	689

## CAPACITY OF AIR IN CUBIC METER PER HOUR

SET PRE-SURE IN	ORIFICE LETTER DESIGNATION													
	D	E	F	G	H	J	K	L	M	N	P	Q	R	T
1	0.04	0.05	0.09	0.13	0.21	0.34	0.49	0.76	0.96	1.15	1.68	2.93	4.25	6.92
2	0.05	0.08	0.13	0.19	0.30	0.50	0.71	1.10	1.69	1.67	2.45	4.25	6.17	10.05
3	0.07	0.10	0.17	0.26	0.41	0.67	0.95	1.47	1.85	2.23	3.28	5.70	8.27	13.45
4	0.09	0.13	0.22	0.33	0.51	0.83	1.19	1.85	2.33	2.80	4.13	7.15	10.37	16.88
5	0.11	0.16	0.26	0.39	0.61	1.00	1.43	2.22	2.80	2.38	4.97	8.62	12.48	20.32
6	0.12	0.18	0.30	0.46	0.72	1.17	1.67	2.60	3.28	3.95	5.82	10.07	14.60	23.75
7	0.14	0.21	0.35	0.53	0.82	1.34	1.92	2.97	3.75	4.52	6.65	11.52	16.70	27.18
8	0.15	0.24	0.39	0.59	0.92	1.51	1.15	3.35	4.23	5.10	7.50	12.98	18.82	30.63
9	0.18	0.26	0.44	0.66	1.03	1.68	2.40	3.72	4.70	5.67	8.33	14.43	20.92	34.07
10	0.19	0.29	0.48	0.77	1.13	1.85	2.63	4.10	5.17	6.23	9.18	15.88	23.03	37.50
12	0.23	0.34	0.57	0.86	1.34	2.18	3.12	4.85	6.12	7.38	10.85	18.80	27.25	44.37
14	0.27	0.40	0.66	0.99	1.55	2.52	3.60	5.60	7.07	8.53	12.53	21.72	31.47	51.23
16	0.30	0.45	0.74	1.12	1.75	2.87	4.08	6.35	8.02	9.67	14.22	24.63	35.68	58.10
18	0.34	0.51	0.83	1.26	1.95	3.20	4.58	7.12	8.97	10.82	15.90	27.53	39.92	64.97
20	0.37	0.56	0.92	1.39	2.17	3.53	5.07	7.87	9.92	11.97	17.58	30.45	44.13	71.83
22	0.41	0.61	1.01	1.52	2.37	3.88	5.55	8.62	10.87	13.10	19.27	33.37	48.35	78.70
24	0.44	0.67	1.10	1.65	2.57	4.22	6.03	9.37	11.82	14.25	20.95	36.27	52.57	85.57
26	0.48	0.72	1.19	1.78	2.78	4.57	6.52	10.12	12.77	15.40	22.63	39.18	56.78	92.43
28	0.51	0.77	1.27	1.92	2.98	4.90	7.00	10.87	13.72	16.53	24.32	42.10	61.00	99.30
30	0.55	0.83	1.36	2.05	3.20	5.23	7.48	11.62	14.67	17.68	26.00	45.02	65.23	106.17
32	0.59	0.88	1.45	2.18	3.40	5.58	7.97	12.37	15.62	18.83	27.68	47.92	69.45	113.03
34	0.62	0.93	1.54	2.30	3.62	5.92	8.45	13.13	16.57	19.97	29.35	50.83	73.67	119.90
36	0.66	0.99	1.63	2.43	3.82	6.25	8.93	13.88	17.52	21.12	31.03	53.75	77.88	126.78
38	0.69	1.04	1.70	2.57	4.02	6.60	9.42	14.63	18.47	22.27	32.72	56.65	82.10	133.65
40	0.73	1.09	1.80	2.70	4.23	6.93	9.90	15.38	19.42	23.40	34.40	59.57	86.32	140.52
42	0.76	1.15	1.88	2.83	4.43	7.27	10.38	16.13	20.37	24.55	36.08	62.48	90.55	147.38
44	0.80	1.20	1.97	2.97	4.65	7.62	10.88	16.88	21.32	25.70	37.77	65.40	94.77	154.25
46	0.84	1.25	2.05	3.10	4.85	7.95	11.37	17.63	22.27	26.83	39.45	68.30	98.98	161.12
48	0.87	1.31	2.15	3.23	5.07	8.30	11.85	18.40	23.22	27.98	41.13	71.22	103.20	167.98
50	0.91	1.36	2.23	3.37	5.27	8.63	12.33	19.15	24.17	29.13	42.82	74.13	107.42	174.85
60	1.08	1.63	2.67	4.03	6.30	10.33	14.75	22.90	28.90	34.85	51.22	88.68	128.52	209.18
70	1.26	1.88	3.12	4.70	7.33	12.03	17.18	26.67	33.65	40.57	59.63	103.25	149.62	243.53
80	1.44	2.15	3.55	5.37	8.37	13.72	19.60	30.43	38.40	46.30	68.03	117.80	170.72	277.87
90	1.62	2.42	4.00	6.02	9.42	15.42	22.02	34.18	43.15	52.02	76.45	132.37	191.82	312.22
100	1.78	2.68	4.43	6.68	10.45	17.12	24.45	37.95	47.88	57.73	84.87	146.92	212.90	346.55
110	1.97	2.95	4.87	7.35	11.48	18.82	26.87	41.72	52.63	63.45	93.27			
120	2.15	3.22	5.32	8.02	12.52	20.52	29.28	45.48	57.38	69.18	101.68			
130	2.32	3.48	5.75	8.68	13.55	22.20	31.72	49.23	62.13	74.90	110.08			
140	2.50	3.75	6.20	9.33	14.58	23.90	34.13	53.00	66.88	80.62	118.50			
150	2.68	4.02	6.63	10.00	15.63	25.60	36.57	56.77	71.62	86.35	126.90			
160	2.85	4.28	7.08	10.67	16.67	27.30	38.98	60.52	76.37	92.07	135.32			
170	3.03	4.55	7.52	11.33	17.70	29.00	41.40	64.28	81.12	97.78	143.72			
180	3.22	4.82	7.95	12.00	18.73	30.68	43.83	68.05	85.87	103.52	152.13			
190	3.38	5.08	8.40	12.65	19.77	32.38	46.25	71.80	90.60	109.23	160.55			
200	3.57	5.35	8.83	13.32	20.80	34.08	48.67	75.57	95.35	114.95	168.95			
210	3.75	5.62	9.28	13.98	21.83	35.78	51.10	79.33	100.10	120.67	177.37			
220	3.92	5.88	9.72	14.65	22.88	37.48	53.52	83.08	104.85	126.40	185.77			
230	4.10	6.15	10.15	15.32	23.92	39.17	55.95	86.85	109.60	132.12	194.18			
240	4.28	6.42	10.60	15.97	24.95	40.87	58.37	90.62	114.33	137.83	202.58			
250	4.45	6.68	11.03	16.63	25.98	42.57	60.78	94.37	119.08	143.57	211.00			
260	4.63	6.95	11.48	17.30	27.02	44.27	63.22	98.13	123.83	149.28	219.40			
270	4.82	7.22	11.90	17.97	28.05	45.97								
280	4.98	7.48	12.35	18.62	29.08	47.65								
290	5.17	7.77	12.80	19.28	30.13	49.35								
300	5.35	8.03	13.23	19.95	31.17	51.05								
310	5.53	8.30	13.68	20.62	32.20	52.75								
320	5.70	8.57	14.12	21.28	33.23	54.45								
330	5.88	8.83	14.57	21.93	34.27	56.15								
340	6.07	9.10	15.00	22.60	35.30	57.83								
350	6.23	9.37	15.43	23.27	36.35	59.53								
370	6.60	9.90	16.32	24.60	38.42	62.93								
390	6.95	10.43	17.20	25.92	40.48	66.32								
410	7.30	10.97	18.08	27.25	42.55	69.72								
425	7.57	11.37	18.73	28.25	44.12	72.27								

<b>CAPACITY OF WATER IN LITER / MINUTE</b>														
<b>SET PRE-SURE IN</b>	<b>ORIFICE LETTER DESIGNATION</b>													
	<b>D</b>	<b>E</b>	<b>F</b>	<b>G</b>	<b>H</b>	<b>J</b>	<b>K</b>	<b>L</b>	<b>M</b>	<b>N</b>	<b>P</b>	<b>Q</b>	<b>R</b>	<b>T</b>
1	68.6	103	172	261	408	671	595	1490	1880	2267	3333	5773	8366	13619
2	93.4	141	234	353	553	908	1297	2015	2544	3067	4508	7807	11315	18418
3	114	173	286	433	677	1111	1587	2465	3111	3751	5514	9548	13837	22524
4	132	200	331	500	782	1283	1833	2847	3593	4331	6367	11026	15978	26009
5	148	224	370	559	875	1434	2049	3183	4017	4843	7119	12327	17864	29079
6	166	248	409	616	961	1575	2248	3490	4404	5309	7802	13507	19573	31857
7	179	268	442	665	1038	1701	2428	3770	4756	5734	8427	14598	21141	34410
8	191	286	472	711	1110	1818	2596	4030	5085	6130	9009	15597	22600	36786
9	203	304	501	754	1177	1928	2754	4274	5393	6501	9555	16543	23971	39017
10	214	320	528	795	1241	2033	2902	4505	5685	6853	10072	17438	25268	41128
12	231	348	575	868	1357	2224	3176	4932	6225	7504	11030	19099	27677	45050
14	250	376	621	937	1465	2402	3431	5328	6723	8106	11914	20629	29894	48660
16	267	402	664	1002	1567	2568	3668	5696	7188	8665	12737	2254	31959	52020
18	283	426	705	1063	1662	2724	3891	6042	7624	9191	13510	23392	33897	55175
20	299	450	743	1121	1752	2871	4101	6368	8037	9689	14241	24657	35731	58160
22	318	476	784	1180	1842	3016	4306	6683	8433	10166	14940	25868	37479	61003
24	332	497	818	1232	1923	3150	4497	6981	8808	10618	15604	27015	39146	63715
26	345	517	852	1282	2002	3278	4681	7165	9167	11051	16241	28118	40744	66317
28	358	537	884	1331	2077	3402	4857	7540	9513	11468	16854	29179	42282	68820
30	371	555	915	1377	2150	3521	5028	7804	9847	11871	17446	30203	43766	71236
32	379	569	941	1419	2217	3633	5189	8056	10166	12256	18014	31190	45197	73568
34	391	587	970	1462	2285	3745	5348	8304	10479	12633	18568	32150	46588	75832
36	402	604	998	1505	2351	3853	5504	8545	10783	12999	19107	33082	47939	78031
38	413	621	1025	1546	2416	3959	5654	8779	11079	13356	19630	33989	49253	80169
40	424	637	1052	1586	2479	4062	5801	9007	11366	13703	20140	34872	50532	82252
42	433	652	1077	1625	2539	4161	5944	9229	11646	14040	20637	35732	51779	84282
44	444	667	1102	1663	2599	4259	6084	9446	11920	14371	21123	36573	52998	86265
46	454	682	1127	1700	2657	4355	6220	9659	12188	14694	21597	37395	54189	88204
48	464	697	1152	1737	2715	4449	6354	9866	12451	15010	22062	38199	55355	90101
50	473	711	1175	1773	2771	4541	6485	10070	12707	15319	22517	38987	56496	91960
60	520	781	1289	1943	3036	4975	7106	11032	13922	16783	24667	42709	61890	100738
70	561	843	1392	2099	3280	5374	7675	11916	15037	18128	26644	46132	66849	108810
80	600	903	1489	2244	3507	5745	8205	12739	16076	19380	28484	49317	71465	116323
90	637	957	1579	2381	3719	6094	8703	13512	17051	20555	30212	52309	75800	123379
100	672	1009	1665	2510	3921	6424	9174	14243	17973	21667	31846	55138	79900	130053
110	704	1058	1746	2632	4112	6738	9622	14939	18851	22725	33401			
120	736	1105	1824	2749	4295	7037	10020	15603	19689	23736	34886			
130	766	1150	1898	2862	4471	7325	10461	16240	20493	24705	36311			
140	795	1194	1970	2970	4640	7601	10855	16853	21267	25638	37681			
150	823	1236	2039	3074	4802	7868	11237	17445	22013	26538	39004			
160	850	1277	2106	3175	4960	8126	11605	18017	22735	27408	40283			
170	876	1316	2171	3273	5113	8376	11962	18572	23435	28252	41523			
180	902	1354	2234	3368	5261	8619	12309	19110	24115	29071	42727			
190	927	1391	2296	3460	5405	8856	12647	19634	24776	29867	43898			
200	951	1427	2355	3550	5546	9086	12975	20144	25419	30643	45038			
210	974	1463	2414	3638	5683	9310	13269	20642	26047	31400	46151			
220	997	1497	2470	3724	5817	9529	13609	21128	26660	32139	47237			
230	1020	1531	2526	3807	5947	9744	13915	21602	27259	32862	48293			
240	1042	1564	2580	3889	6075	9953	14214	22067	27846	33568	49337			
250	1063	1599	2634	3970	6201	10158	14507	22522	28420	34261	50355			
260	1084	1628	2686	4048	6324	10360	14794	22968	28983	34939	51352			
270	1105	1659	2737	4125	6444	10557								
280	1125	1689	2787	4201	6562	10751								
290	1145	1719	2837	4275	6679	10941								
300	1165	1749	2885	4349	6793	11128								
310	1184	1778	2933	4421	6905	11312								
320	1203	1806	2980	4491	7016	11493								
330	1222	1834	3026	4561	7124	11672								
340	1240	1862	3072	4630	7232	11847								
350	1259	1889	3117	4697	7337	12020								
370	1294	1942	3205	4830	7544	12359								
390	1329	1994	3290	4959	7745	12689								
410	1362	2045	3373	5084	7941	13010								
425	1387	2082	3435	5176	8058	13246								

## CAPACITY OF STEAM IN KG / HOUR AT SATURATED TEMPERATURE

SET PRE-SSURE IN	ORIFICE LETTER DESIGNATION													
	D	E	F	G	H	J	K	L	M	N	P	Q	R	T
1	98	147	241	363	566	926	1321	2051	2587	3119	4583	7933	11495	18709
2	142	212	349	526	820	1342	1916	2974	2752	4523	6647	11507	16673	27137
3	186	278	457	688	1074	1759	2511	3897	4917	5927	8711	15080	21851	35566
4	230	344	565	851	1329	2175	3106	4820	6082	7332	10775	18654	27030	43995
5	237	409	674	1014	1583	2592	3700	5744	7247	8736	12839	22227	32208	52423
6	313	471	778	1173	1833	3004	4291	6663	8408	10136	14899	25797	37382	60848
7	257	536	886	1336	2087	3421	4886	7586	9573	11541	16963	29370	42561	69276
8	400	602	994	1498	2342	3837	5481	8509	10738	12945	19027	32944	47739	77705
9	444	667	1102	1661	2596	4254	6075	9433	11903	14349	21091	36517	52917	68133
10	488	733	1210	1824	2850	4670	6670	10356	13068	15754	23155	40091	58095	94562
12	578	867	1429	2153	3362	5506	7862	12205	15401	18566	27286	47241	68455	111422
14	665	998	1645	2478	2870	6339	9052	14052	17731	21374	31414	54388	78812	128279
16	753	1129	1861	2804	4379	7172	10241	15898	20061	24183	35542	61535	89168	145136
18	840	1260	2077	3130	4887	8005	11431	17745	22391	26992	39670	68682	99525	161993
20	928	1391	2293	3455	5396	8838	12620	19591	24721	29801	43798	75829	109881	178850
22	1013	1520	2507	3779	5902	9669	13808	21436	27049	32607	47924	82974	120236	195705
24	1100	1651	2723	4104	6411	10502	14997	23282	29378	35416	52052	90122	130592	212563
26	1188	1782	2940	4430	9619	11335	16186	25129	31708	38225	56181	97269	140949	229420
28	1275	1913	3156	4756	7428	12168	17376	26975	34038	41034	60309	104416	151306	246277
30	1362	2044	3372	5081	7936	13001	1865	28822	36368	43842	64437	111563	161662	263134



## The Following Calculation are Presented in U. S. Customary Units

### Nomenclature :-

- A** = Required orifice area in square inches. This value may be compared with API effective areas included in this catalog and defined in ANSI/API standards 526 or ASME actual area.
- W** = Required vapor capacity in pounds per hour.
- W<sub>s</sub>** = Required steam capacity in pounds per hour.
- V** = Required gas capacity in SCFM.
- V<sub>l</sub>** = Required liquid capacity in U. S. gallons per minute.
- G** = Specific gravity of gas (Air=1) or specific gravity of liquid (Water=1) at actual discharge temperature.
- M** = Average molecular weight of vapor.
- P** = Relieving pressure in psig = set pressure + over pressure + 14.7 minimum over pressure is 10% or 3 psig, whichever is greater.
- P<sub>1</sub>** = Set pressure at inlet, psig.
- P<sub>2</sub>** = Back pressure at outlet, psig.
- ΔP** = Set pressure + Over pressure, psig-back pressure, psig at 10% over pressure triangle P = 1.1P1-P2 below 30 psig set, triangle P=P1+3-P2
- T** = Inlet temperature absolute (OF+460)
- Z** = Compressibility factor corresponding to T and P (if this factor is not available, compressibility correction can be safely ignored by using a value of Z=1.0.
- C** = Gas or vapor flow constant.
- K** = Ratio of specific heats CP/CT. This value is constant for and ideal gas. If this ratio is unknown the value K = 1.001, C = 315 will result in a safe valve size. Isentropic co-efficient and may be used instead of K.
- K<sub>p</sub>** = Vapor or gas flow correction factor for back pressures above critical pressure. See curve.
- K<sub>v</sub>** = Liquid viscosity correction factor.
- K<sub>sh</sub>** = Steam superheat correction factor. KSH = 1 for saturated steam.
- K<sub>n</sub>** = Napier steam correction factor for set pressures between 1500 and 2900 psig.
- K<sub>d</sub>** = Coefficient of discharge.

ORIFICE AREA CALCULATIONS	CONSTANT BACK PRESSURE
<p><b>Vapors or Gases-Lbs/Hr.</b></p> $A = \frac{W\sqrt{T}\sqrt{Z}}{CK_d P \sqrt{MK_b}}$	K <sub>b</sub> = 1 when back pressure is below 55% of abs. relieving pressure.
<p><b>Vapors or Gases-S.C.F.M.</b></p> $A = \frac{V\sqrt{G}\sqrt{T}\sqrt{Z}}{1.175CK_d PK_b}$	K <sub>b</sub> = 1 when back pressure is below 55% of abs. relieving pressure.
<p><b>Steam - Lbs./Hr.</b></p> $A = \frac{W_s}{51.5K_d PK_b K_{sh} K_n}$	K <sub>b</sub> = 1 when back pressure is below 55% of abs. relieving pressure. K <sub>sh</sub> = 1 for sat. steam
<p><b>Air - S.C.F.M.</b></p> $A = \frac{V_3\sqrt{T}}{418K_d PK_b}$	K <sub>b</sub> = 1 when back pressure is below 55% of abs. relieving pressure.
<p><b>Liquids G.P.M., ASME Code</b></p> $A = \frac{V_L\sqrt{G}}{38.0K_d \sqrt{\Delta P} K_u}$	K <sub>u</sub> = 1 at normal viscosities.

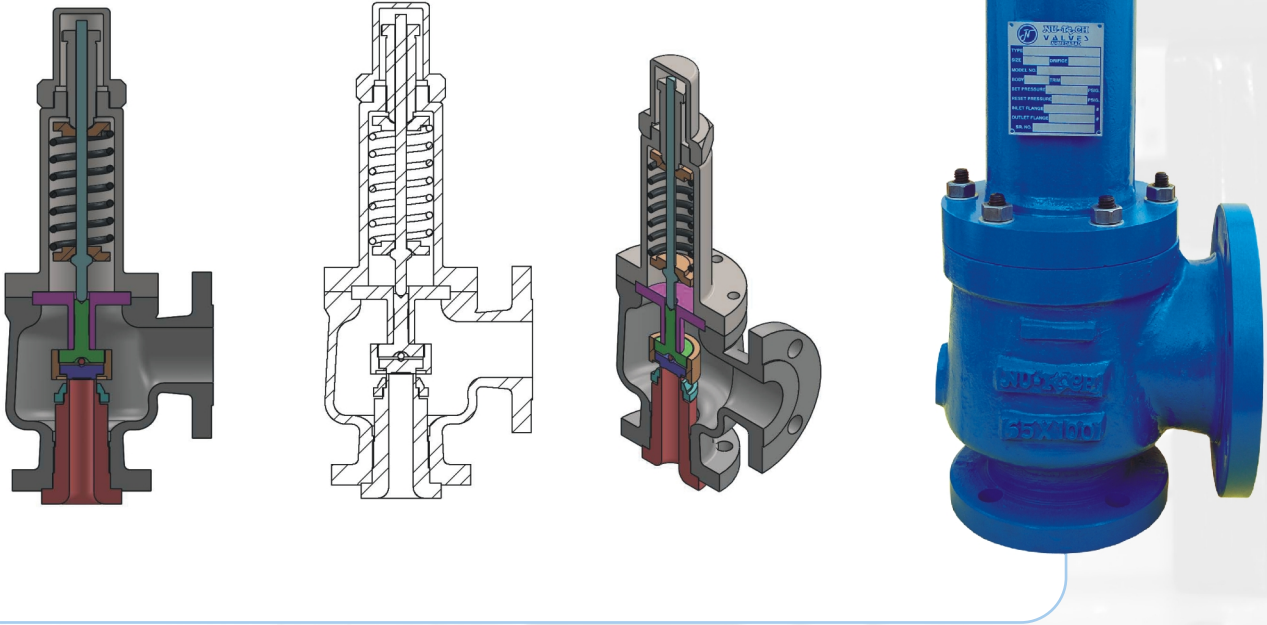

## Nu-tech's API Safety Valves

- ▶ Are designed to meet all applications which require API.
- ▶ Open rapidly with an over pressure of max. 10% to the full design art.
- ▶ Have a maximum blow down of minus 7% for steam/gas services and minus 20% for liquid service.
- ▶ Are developed in a close co-operation with plant engineers and service specialists.
- ▶ Serve for protection of processes and equipment.

**Safety valves present the simple safe solutions for heavy duty applications, such as crude oil extractions, transportation and processing in....**

- ▶ REFINERIES
- ▶ CHEMICAL INDUSTRY
- ▶ PETROCHEMICAL INDUSTRY
- ▶ OIL AND GAS - ONSHORE & OFFSHORE
- ▶ VESSELS AND PIPING SYSTEM
- ▶ BLOW-DOWN SYSTEMS
- ▶ STORAGE TANK FARMS

# ORIFICE AND CLASS TABLES - SAFETY RELIEF VALVE

DIMENSIONAL DETAIL - SAFETY RELIEF VALVE							
ORIFICE TYPE	SIZE	CLASS	ORIFICE DIAMETER (D)	ORIFICE AREA (A)	CENTER TO BOTTOM (C/B)	CENTER TO FACE (C/F)	HEIGHT (H)
D & E	1x2	150x150	14	154	105	114	440
	1x2	300Lx150	14	154	105	114	440
	1x2	300x150	14	154	105	114	440
	1x2	600x150	14	154	105	114	440
	1-1/2x2	900x300	14	154	105	140	517
	1-1/2x2	1500x300	14	154	105	140	517
F	1-1/x23	2500x300	14	154	140	178	576
	1x2	150x150	18	254	124	121	536
	1x2	300Lx150	18	254	124	121	536
	1x2	300x150	18	254	124	152	536
	1x2	600x150	18	254	124	152	536
	1-1/2x3	900x300	18	254	124	165	560
	1-1/2x3	1500x300	18	254	124	165	560
G	1-1/2x3	2500x300	18	254	140	178	576
	1-1/2x3	150x150	22.5	398	140	121	536
	1-1/2x3	300Lx150	22.5	398	124	121	536
	1-1/2x3	300x150	22.5	398	124	152	536
	1-1/2x3	600x150	22.5	398	124	152	536
	1-1/2x3	900x300	22.5	398	124	165	560
	2x3	1500x300	22.5	398	124	172	688
H	2x3	2500x300	22.5	398	156	172	688
	1-1/2x3	150x150	28.3	629	156	124	542
	1-1/2x3	300Lx150	28.3	629	130	124	542
	2x3	300x150	28.3	629	130	124	666
	2x3	600x150	28.3	629	130	162	691
	2x3	900x150	28.3	629	154	162	691
	2x3	1500x300	28.3	629	154	162	691
J	2x3	150x150	36	1018	154	124	673
	2x3	300Lx150	36	1018	137	124	673
	3x4	300x150	36	1018	137	181	786
	3x4	600x150	36	1018	184	181	786
	3x4	900x150	36	1018	184	181	786
	3x4	1500x300	36	1018	184	181	786
K	3x4	150x150	43	1452	184	162	758
	3x4	300Lx150	43	1452	156	162	758
	3x4	300x150	43	1452	156	162	758
	3x4	600x150	43	1452	156	162	786
	4x6	900x150	43	1452	184	181	880
	4x6	1500x300	43	1452	198	216	879
	3x4	2500x300	43	1452	184	181	786
L	3x4	150x150	53.5	2248	197	216	758
	4x6	300Lx150	53.5	2248	156	165	758
	4x6	300x150	53.5	2248	156	165	83
	4x6	600x150	53.5	2248	179	181	853
	4x6	900x150	53.5	2248	179	203	871
	4x6	1500x150	53.5	2248	197	222	871
	4x6	2500x300	53.5	2248	198	216	879
M	4x6	150x150	60.3	2856	178	184	852
	4x6	300Lx150	60.3	2856	178	184	852
	4x6	300x150	60.3	2856	178	184	852
	4x6	600x150	60.3	2856	178	203	852
	4x6	900x150	60.3	2856	197	222	871
N	4x6	150x150	66	3421	197	210	871
	4x6	300Lx150	66	3421	197	210	871
	4x6	300x150	66	3421	197	210	871
	4x6	600x150	66	3421	197	222	871
	4x6	900x150	66	3421	197	222	871
P	4x6	150x150	80	5027	181	229	855
	4x6	300Lx150	80	5027	181	229	855
	4x6	300x150	80	5027	225	254	1079
	4x6	600x150	80	5027	225	254	1079
	4x6	900x150	80	5027	225	254	1079
Q	6x8	150x150	105.5	8742	240	241	1120
	6x8	300Lx150	105.5	8742	240	241	1120
	6x8	300x150	105.5	8742	240	241	1120
	6x8	600x150	105.5	8742	240	241	1120
R	6x8	150x150	126.5	12568	240	241	1120
	6x8	300Lx150	126.5	12568	240	241	1120
	6x10	300x150	126.5	12568	240	241	1426
	6x10	600x150	126.5	12568	240	241	1426
T	8x10	150x150	161.5	20485	276	279	1462
	8x10	300Lx150	161.5	20485	276	279	1462
	8x10	300x150	161.5	20485	276	279	1462

CAPACITY OF AIR IN CUBIC METER PER HOUR														
SET PRE-SURE IN	ORIFICE LETTER DESIGNATION													
	D	E	F	G	H	J	K	L	M	N	P	Q	R	T
1	0.04	0.05	0.09	0.13	0.21	0.34	0.49	0.76	0.96	1.15	1.68	2.93	4.25	6.92
2	0.05	0.08	0.13	0.19	0.30	0.50	0.71	1.10	1.39	1.67	2.45	4.25	6.17	10.03
3	0.07	0.10	0.17	0.26	0.41	0.66	0.95	1.47	1.85	2.23	3.28	5.70	8.25	13.43
4	0.09	0.13	0.22	0.33	0.51	0.83	1.19	1.83	2.32	2.80	4.12	7.15	10.37	16.87
5	0.11	0.16	0.26	0.39	0.61	1.00	1.43	2.22	2.80	3.38	4.97	8.60	12.47	20.30
6	0.12	0.18	0.30	0.46	0.72	1.17	1.67	2.60	3.27	3.95	5.80	10.05	14.58	23.73
7	0.14	0.21	0.35	0.52	0.82	1.34	1.92	2.97	3.75	4.52	6.65	11.52	16.68	27.17
8	0.15	0.24	0.39	0.59	0.92	1.51	2.15	3.35	4.22	5.08	7.48	12.97	18.78	30.58
9	0.18	0.26	0.44	0.66	1.03	1.67	2.40	3.72	4.70	5.67	8.32	14.42	20.90	34.02
10	0.19	0.29	0.48	0.72	1.13	1.85	2.63	4.10	5.17	6.23	9.17	15.87	23.00	37.45
12	0.23	0.34	0.57	0.86	1.34	2.18	3.12	4.85	6.12	7.38	10.85	18.78	27.22	44.32
14	0.27	0.40	0.66	0.99	1.54	2.52	3.60	5.60	7.07	8.52	12.52	21.68	31.43	51.17
16	0.30	0.45	0.74	1.12	1.75	2.87	4.08	6.35	8.02	9.67	14.20	24.60	35.65	58.03
18	0.34	0.50	0.83	1.25	1.95	3.20	4.57	7.10	8.97	10.80	15.88	27.50	39.87	64.88
20	0.37	0.56	0.92	1.39	2.15	3.53	5.05	7.85	9.92	11.95	17.57	30.42	44.08	71.75
22	0.41	0.61	1.01	1.52	2.37	3.88	5.53	8.60	10.85	13.08	19.25	33.32	48.30	
24	0.44	0.66	1.10	1.65	2.57	4.22	6.02	9.35	11.80	14.23	20.92	36.23	52.50	
26	0.48	0.72	1.18	1.78	2.78	4.55	6.50	10.10	12.75	15.38	22.60	39.13	56.27	
28	0.51	0.77	1.27	1.90	2.98	4.90	6.98	10.85	13.70	16.52	24.28	42.05	60.93	
30	0.55	0.82	1.36	2.03	3.18	5.23	7.47	11.62	14.65	17.67	25.97	44.95	65.15	
32	0.59	0.88	1.45	2.17	3.40	5.57	7.97	12.37	15.60	18.80	27.65	47.87	69.37	
34	0.62	0.93	1.54	2.30	3.60	5.92	8.45	13.12	16.55	19.95	29.32	50.77	73.58	
36	0.66	0.98	1.62	2.43	3.82	6.25	8.93	13.87	17.50	21.10	31.00	53.68	77.80	
38	0.69	1.04	1.70	2.57	4.02	6.58	9.42	14.62	18.45	22.23	32.68	56.58	82.00	
40	0.73	1.09	1.78	2.70	4.23	6.93	9.90	15.37	19.38	23.38	34.37	59.50	86.22	
42	0.76	1.14	1.88	2.83	4.43	7.27	10.38	16.12	20.33	24.52	36.05	62.42		
44	0.80	1.20	1.97	2.97	4.63	7.60	10.87	16.87	21.28	25.67	37.72	65.32		
46	0.83	1.25	2.05	3.10	4.85	7.95	11.35	17.62	22.23	26.80	39.40	68.23		
48	0.87	1.30	2.15	3.23	5.05	8.28	11.83	18.37	23.18	27.95	41.08	71.13		
50	0.91	1.36	2.23	3.37	5.27	8.62	12.32	19.12	24.13	29.10	42.77	740.5		
60	1.08	1.62	2.67	4.03	6.30	10.32	14.73	22.88	28.87	34.80	51.17	88.58		
70	1.26	1.88	3.12	4.68	7.33	12.02	17.15	26.63	33.62					
80	1.44	2.15	3.55	5.35	8.37	13.70	19.58	30.40						
90	0.62	2.42	3.98	6.02	9.40	15.40	22.00	34.15						
100	1.78	2.68	4.43	6.68	10.43	17.10	24.42	37.90						
110	1.97	2.95	4.87	7.33	11.47	18.78	26.83							
120	2.13	3.22	5.32	8.00	12.50	20.48	29.25							
130	2.32	3.48	5.75	8.67	13.53	22.18	31.68							
140	2.50	3.75	6.18	9.33	14.57	23.88	34.10							
150	2.67	4.02	6.63	9.98	15.60	25.57	36.52							
160	2.85	4.28	7.07	10.65	16.65	27.27								
170	3.03	4.55	7.50	11.32	17.68	28.97								
180	3.20	4.82	7.95	11.98	18.72	30.65								
190	3.38	4.08	8.38	12.62										
200	3.57	5.35	8.83	13.30										
210	3.73	5.62	9.27	13.97										
220	3.92	5.88	9.70	14.63										
230	4.10	6.15	10.15	15.28										
240	4.27	6.42	10.58	15.95										
250	4.45	6.68	11.02	16.62										
260	4.63	6.95	11.47											
270	4.80	7.22	11.90											
280	4.98	7.48	12.35											
290	5.17	7.75	12.78											
300	5.33	8.02	13.22											
310	5.52	8.28	13.67											
320	5.70	8.55	14.10											
330	5.87	8.82	14.55											
340	6.05	9.08	14.98											
350	6.23	9.35												
360	6.40	9.62												
370	6.58	9.88												
380	6.77	10.15												
390	6.93	10.42												
400	7.12	10.68												

# SAFETY RELIEF VALVE - WATER CAPACITY

<b>CAPACITY OF WATER IN LITER / MINUTE</b>														
<b>SET PRE-SSURE IN</b>	<b>ORIFICE LETTER DESIGNATION</b>													
	<b>D</b>	<b>E</b>	<b>F</b>	<b>G</b>	<b>H</b>	<b>J</b>	<b>K</b>	<b>L</b>	<b>M</b>	<b>N</b>	<b>P</b>	<b>Q</b>	<b>R</b>	<b>T</b>
1	56.8	86.2	143	217	340	559	799	1242	1567	1890	2779	4813	6975	11355
2	77.6	117	194	267	461	456	1081	1680	2120	2557	3759	5609	9433	15356
3	95.3	14	238	360	564	926	1323	2055	2593	3127	4597	7960	11536	18779
4	110	166	276	416	652	1069	1528	2373	2995	3611	5308	9192	13321	21684
5	123	186	308	466	729	1196	1708	2653	3349	4038	5935	10278	14894	24244
6	136	205	339	512	800	1311	1873	2908	3670	4424	65.3	11260	16317	26560
7	147	222	366	553	864	1416	2023	3141	3964	4779	7024	12162	17624	28688
8	157	237	382	591	924	1514	2163	3358	4238	5109	7509	13002	18841	30669
9	167	251	416	627	980	1606	2294	3562	4495	5419	7965	13791	19984	32529
10	176	265	438	661	1033	1693	2418	3755	4738	5712	8396	14537	21065	34289
12	195	293	482	726	1134	1857	2651	4115	5192	6259	9199	15926	23078	37563
14	211	316	521	784	1224	2005	2863	4445	5608	6761	9936	172.03	24927	40573
16	225	338	557	838	1309	2144	3061	4752	5996	7227	10622	18390	26648	43374
18	263	355	587	886	1385	2271	3244	5037	6356	7663	11263	19503	28262	46003
20	249	375	619	934	1460	2394	3419	5309	6700	8078	11873	20558	29791	
22	265	397	654	984	1536	2515	3590	5573	7031	8476	12457	21565	31249	
24	277	415	683	1028	1604	2626	3750	5820	7344	8853	13010	22524	32638	
26	288	431	710	1069	1669	2734	3903	6058	7644	9214	13542	23444	33971	
28	295	444	733	1106	1728	2833	4046	6283	7928	9558	14049	24325	35249	
30	305	459	759	1145	1789	2932	4188	6503	8207	9893	14542	25179	36487	
32	318	477	787	1185	1851	3031	4329	6717	8476	10218	15019	26004		
34	328	492	811	1222	1908	3125	4462	6923	8737	10533	15481	26805		
36	338	506	835	1257	1963	3215	4591	7124	8990	10838	15930	27582		
38	344	517	854	1289	2014	3300	4714	7319	9236	11135	16367	28338		
40	353	531	877	1322	2066	3386	4837	7510	9476	11424	16792	29074		
42	362	544	898	1355	2117	3470	4956	7695	9711	11707	17207	29792		
44	370	557	920	1397	2167	3552	5073	7876	9939	11982	17612			
46	379	569	940	1418	2216	3632	5187	8053	10163	12251	18007			
48	387	582	961	1449	2264	3710	5398	8227	10381					
50	395	594	980	1479	2310	3786	5408	8396	10595					
60	433	651	1074	1620	2531	4148	5924	9198						
70	468	703	1161	1750	2734	4480	6399	9935						
80	500	752	1241	1871	2923	4790	6841	10621						
90	531	797	1316	1985	3101	5081	7256	11266						
100	560	841	1388	2092	3269	5356	7649	11875						
110	587	882	1455	2194	3428	5617	8022	12455						
120	613	921	1520	2292	3581	5867	8379	13009						
130	638	959	1582	2386	3727	6107	8721	13540						
140	663	995	1642	2476	3868	6337	9050							
150	686	1030	1700	2563	4004	6560	9368							
160	708	1064	1756	2647	4135	6775	9876							
170	730	1097	1810	2728	4262	6984	9973							
180	752	1129	1863	2808	4386	7186	10263							
190	772	1160	1914	2885	4506	7383	10544							
200	792	1190	1963	2960	4623	7575	10818							
210	812	1219	2012	3033	4738	7762	11085							
220	831	1248	2059	3104	4849	7945	11346							
230	850	1276	2106	3174	4958	8123	11601							
240	868	1304	2151	3242	5065	8298	11851							
250	886	1330	2195	3309	5169	8469								
260	904	1357	2239	3375	5272	8637								
270	921	1383	2282	3439	5372	8802								
280	938	1408	2324	3502	5471	8963								
290	855	1433	2365	3564	5568	9122								
300	971	1458	2405	3625										

## CAPACITY OF STEAM IN KG/HOUR AT SATURATED TEMPERATURE

SET PRESSURE IN	ORIFICE LETTER DESIGNATION													
	D	E	F	G	H	J	K	L	M	N	P	Q	R	T
1	68.6	103	172	261	408	671	595	1490	1880	2267	3333	5773	8366	13619
2	93.4	141	234	353	553	908	1297	2015	2544	3067	4508	7807	11315	18418
3	114	173	286	433	677	1111	1587	2465	3111	3751	5514	9548	13837	22524
4	132	200	331	500	782	1283	1833	2847	3593	4331	6367	11026	15978	26009
5	148	224	370	559	875	1434	2049	3183	4017	4843	7119	12327	17864	29079
6	166	248	409	616	961	1575	2248	3490	4404	5309	7802	13507	19573	31857
7	179	268	442	665	1038	1701	2428	3770	4756	5734	8427	14598	21141	34410
8	191	286	472	711	1110	1818	2596	4030	5085	6130	9009	15597	22600	36786
9	203	304	501	754	1177	1928	2754	4274	5393	6501	9555	16543	23971	39017
10	214	320	528	795	1241	2033	2902	4505	5685	6853	10072	17438	25268	41128
12	231	348	575	868	1357	2224	3176	4932	6225	7504	11030	19099	27677	45050
14	250	376	621	937	1465	2402	3431	5328	6723	8106	11914	20629	29894	48660
16	267	402	664	1002	1567	2568	3668	5696	7188	8665	12737	2254	31959	52020
18	283	426	705	1063	1662	2724	3891	6042	7624	9191	13510	23392	33897	55175
20	299	450	743	1121	1752	2871	4101	6368	8037	9689	14241	24657	35731	58160
22	318	476	784	1180	1842	3016	4306	6683	8433	10166	14940	25868	37479	61003
24	332	497	818	1232	1923	3150	4497	6981	8808	10618	15604	27015	39146	63715
26	345	517	852	1282	2002	3278	4681	7165	9167	11051	16241	28118	40744	66317
28	358	537	884	1331	2077	3402	4857	7540	9513	11468	16854	29179	42282	68820
30	371	555	915	1377	2150	3521	5028	7804	9847	11871	17446	30203	43766	71236
32	379	569	941	1419	2217	3633	5189	8056	10166	12256	18014	31190	45197	73568
34	391	587	970	1462	2285	3745	5348	8304	10479	12633	18568	32150	46588	75832
36	402	604	998	1505	2351	3853	5504	8545	10783	12999	19107	33082	47939	78031
38	413	621	1025	1546	2416	3959	5654	8779	11079	13356	19630	33989	49253	80169
40	424	637	1052	1586	2479	4062	5801	9007	11366	13703	20140	34872	50532	82252
42	433	652	1077	1625	2539	4161	5944	9229	11646	14040	20637	35732	51779	84282
44	444	667	1102	1663	2599	4259	6084	9446	11920	14371	21123	36573	52998	86265
46	454	682	1127	1700	2657	4355	6220	9659	12188	14694	21597	37395	54189	88204
48	464	697	1152	1737	2715	4449	6354	9866	12451	15010	22062	38199	55355	90101
50	473	711	1175	1773	2771	4541	6485	10070	12707	15319	22517	38987	56496	91960
60	520	781	1289	1943	3036	4975	7106	11032	13922	16783	24667	42709	61890	100738
70	561	843	1392	2099	3280	5374	7675	11916	15037	18128	26644	46132	66849	108810
80	600	903	1489	2244	3507	5745	8205	12739	16076	19380	28484	49317	71465	116323
90	637	957	1579	2381	3719	6094	8703	13512	17051	20555	30212	52309	75800	123379
100	672	1009	1665	2510	3921	6424	9174	14243	17973	21667	31846	55138	79900	130053
110	704	1058	1746	2632	4112	6738	9622	14939	18851	22725	33401			
120	736	1105	1824	2749	4295	7037	10020	15603	19689	23736	34886			
130	766	1150	1898	2862	4471	7325	10461	16240	20493	24705	36311			
140	795	1194	1970	2970	4640	7601	10855	16853	21267	25638	37681			
150	823	1236	2039	3074	4802	7868	11237	17445	22013	26538	39004			
160	850	1277	2106	3175	4960	8126	11605	18017	22735	27408	40283			
170	876	1316	2171	3273	5113	8376	11962	18572	23435	28252	41523			
180	902	1354	2234	3368	5261	8619	12309	19110	24115	29071	42727			
190	927	1391	2296	3460	5405	8856	12647	19634	24776	29867	43898			
200	951	1427	2355	3550	5546	9086	12975	20144	25419	30643	45038			
210	974	1463	2414	3638	5683	9310	13269	20642	26047	31400	46151			
220	997	1497	2470	3724	5817	9529	13609	21128	26660	32139	47237			
230	1020	1531	2526	3807	5947	9744	13915	21602	27259	32862	48293			
240	1042	1564	2580	3889	6075	9953	14214	22067	27846	33568	49337			
250	1063	1599	2634	3970	6201	10158	14507	22522	28420	34261	50355			
260	1084	1628	2686	4048	6324	10360	14794	22968	28983	34939	51352			
270	1105	1659	2737	4125	6444	10557								
280	1125	1689	2787	4201	6562	10751								
290	1145	1719	2837	4275	6679	10941								
300	1165	1749	2885	4349	6793	11128								
310	1184	1778	2933	4421	6905	11312								
320	1203	1806	2980	4491	7016	11493								
330	1222	1834	3026	4561	7124	11672								
340	1240	1862	3072	4630	7232	11847								
350	1259	1889	3117	4697	7337	12020								
370	1294	1942	3205	4830	7544	12359								
390	1329	1994	3290	4959	7745	12689								
410	1362	2045	3373	5084	7941	13010								
425	1387	2082	3435	5176	8058	13246								

## The Following Calculation are Presented in U. S. Customary Units

### Nomenclature :-

- A** = Required orifice area in square inches. This value may be compared with API effective areas included in this catalog and defined in ANSI/API standards 526 or ASME actual area.
- W** = Required vapor capacity in pounds per hour.
- W<sub>s</sub>** = Required steam capacity in pounds per hour.
- V** = Required gas capacity in SCFM.
- V<sub>a</sub>** = Required air capacity in SCFM.
- V<sub>l</sub>** = Required liquid capacity in U. S. gallons per minute.
- G** = Specific gravity of gas (Air=1) or specific gravity of liquid (Water=1) at actual discharge temperature will obtain a safe valve size.
- M** = Average molecular weight of vapor.
- P** = Relieving pressure in psig = set pressure + over pressure + 14.7 minimum over pressure is 10% or 3 psig.
- P<sub>1</sub>** = Set pressure at inlet, psig.
- P<sub>2</sub>** = Back pressure at outlet, psig.
- ΔP** = Set pressure + Over pressure, psig-back pressure, psig at 10% over pressure triangle P = 1.1P<sub>1</sub>-P<sub>2</sub> below 30 psig set, triangle P=P<sub>1</sub>+3-P<sub>2</sub>
- T** = Inlet temperature absolute (OF+460)
- Z** = Compressibility factor corresponding to T and P (if this factor is not available, compressibility correction can be safely ignored by using a value of Z=1.0).
- C** = Gas or vapor flow constant.
- K** = Ratio of specific heats CP/CT. This value is constant for and ideal gas. If this ratio is unknown the value K = 1.001, C = 315 will result in a safe valve size. Isentropic co-efficient and may be used instead of K.
- K<sub>p</sub>** = Vapor or gas flow correction factor for back pressures above critical pressure. See curve.
- K<sub>v</sub>** = Liquid viscosity correction factor.
- K<sub>sh</sub>** = Steam superheat correction factor. KSH = 1 for saturated steam.
- K<sub>n</sub>** = Napier steam correction factor for set pressures between 1500 and 2900 psig.
- K<sub>d</sub>** = Coefficient of discharge.

ORIFICE AREA CALCULATIONS	CONSTANT BACK PRESSURE
<p style="color: #0070C0;"><b>Vapors or Gases-Lbs/Hr.</b></p> $A = \frac{W\sqrt{T}\sqrt{Z}}{CK_d P \sqrt{MK_b}}$	<p>K<sub>b</sub> = 1 when back pressure is below 55% of abs. relieving pressure.</p>
<p style="color: #0070C0;"><b>Vapors or Gases-S.C.F.M.</b></p> $A = \frac{V\sqrt{G}\sqrt{T}\sqrt{Z}}{1.175CK_d PK_b}$	<p>K<sub>b</sub> = 1 when back pressure is below 55% of abs. relieving pressure.</p>
<p style="color: #0070C0;"><b>Steam - Lbs./Hr.</b></p> $A = \frac{W_s}{51.5K_d PK_b K_{sh} K_n}$	<p>K<sub>b</sub> = 1 when back pressure is below 55% of abs. relieving pressure. K<sub>sh</sub> = 1 for sat. steam</p>
<p style="color: #0070C0;"><b>Air - S.C.F.M.</b></p> $A = \frac{V_3\sqrt{T}}{418K_d PK_b}$	<p>K<sub>b</sub> = 1 when back pressure is below 55% of abs. relieving pressure.</p>
<p style="color: #0070C0;"><b>Liquids G.P.M., ASME Code</b></p> $A = \frac{V_L\sqrt{G}}{38.0K_d \sqrt{\Delta P}K_u}$	<p>K<sub>b</sub> = 1 at 25% over pressure. K<sub>u</sub> = 1 at normal viscosities.</p>
<p style="color: #0070C0;"><b>Liquids G.P.M., Non ASME Code</b></p> $A = \frac{V_L\sqrt{G}}{38.0K_d \sqrt{1.25(P_1-P_2)}K_p K_u}$	

MATERIAL	TEMP. RANGE °F-20 TO 450	D TO K ORIFICE		L TO T ORIFICE	
		SET PRESSURE (PSIG) 15 TO 100	HARDNESS	SET PRESSURE (PSIG) 15 TO 100	HARDNESS
VITON	-20 to 450	101 to 650	75	150 to 450	75
	-20 to 125	650 to 950	75	450 to 750	75
	125 to 450		90		90
	-20 to 450	950 to 1500	90	750 to 1500	90
KALREZ	-20 to 550	15 to 200	65	15 to 150	65
	-20 to 550	201 to 650	80	150 to 450	80
	-20 to 200	650 to 950	80	450 to 750	80
	200 to 550		90		90
	-20 to 550	950 to 1500	90	750 to 1500	90
NEOPRENE	-45 to 300	50 to 750	70	50 to 750	70
	-45 to 300	750 to 1500	80	751 to 1500	80



## APPLICATIONS

- ▶ **Air, Gas Compressors & Pumps**
- ▶ **Technical Gases & CO2 plants.**
- ▶ **Cylinder filling stations.**
- ▶ **Chemical equipments and pipings.**
- ▶ **Pressure vessels and piping systems containing gas, air, liquid or steam.**
- ▶ **LPG/LNG terminates carriers etc.**
- ▶ **Cryogenic systems & oxygen applications.**
- ▶ **Thermal relief.**
- ▶ **High pressure extraction plants.**



- ▶ Are designed to meet all industrial applications up to F orifice
- ▶ Open rapidly with an over pressure of max. 5% resp. 10% to the full design lift.
- ▶ Have a maximum blow down of minus 10% for steam/gas service and minus 20% for liquid service.
- ▶ Are developed in a close co-operation with plant engineers and service specialists.
- ▶ Serve for protection of processes and equipment.
- ▶ Are approved by all important approval organizations worldwide which ensures the worldwide applicability e. g.

Orifice Area MM2	Valve Size Inlet x Outlet	Max. Set Pressure, Barg -45.6° to 399° C	Max. Back Pressure Barg at 37.8° C
43.87	1 / 2x1	700	28
	3 / 4x1	400	
	3 / 4x1	400	
	1 x 1	400	
	1 x 1	400	
80.65	1 / 2x1	300	
	3 / 4x1	110	
	3 / 4x1	345	
	1 x 1	110	
	1 x 1	345	
143.87	1 x 1-1/2	172	
255.81	1-1 / 2x2	110	
396.68	1-1 / 2x2-1 / 2	69	

## THREADED SAFETY VALVE - STEAM CAPACITY

CAPACITY OF STEAM IN KG/HOUR AT SATURATED TEMPERATURE					
SET PRESSURE IN	ORIFICE LETTER DESIGNATION				
	C	D	E	F	G
1	45	81	148	232	379
2	66	120	214	336	549
3	90	161	287	449	735
4	110	202	400	564	922
5	133	243	432	678	1110
6	152	284	505	793	1297
70	177	324	578	907	1484
8	200	365	650	1021	1672
9	221	406	724	1136	1859
10	244	447	797	1250	2046
12	290	529	943	1479	2421
14	333	611	1088	1708	2795
16	377	692	1234	1937	3170
18	421	774	1380	2166	3545
20	463	853	1523	2394	3919
25	574	1057	1887	2966	4855
30	685	1261	2251	3538	5792
35	796	1465	2616	4110	6728
40	907	1670	2980	4682	7665
45	1019	1874	3345	4654	8601
50	1133	2081	3712	5826	9538
55	1244	2285	4077	6398	10474
60	1356	2491	4442	6970	11410
65	1467	2695	4807	7542	12347
70	1577	2899	5170	8114	13283
75	1688	3103	5534	8686	14220

# THREADED SAFETY VALVE - AIR & WATER CAPACITY

CAPACITY OF STEAM IN KG/HOUR AT SATURATED TEMPERATURE					
SET PRE- SSURE IN	ORIFICE LETTER DESIGNATION				
	C	D	E	F	G
1	0.02	0.03	0.06	0.09	0.14
2	0.02	0.05	0.08	0.12	0.20
3	0.03	0.06	0.11	0.17	0.27
4	0.04	0.08	0.13	0.21	0.34
5	0.05	0.09	0.16	0.25	0.41
6	0.06	0.11	0.19	0.29	0.48
7	0.07	0.12	0.21	0.34	0.55
8	0.07	0.14	0.24	0.38	0.62
9	0.08	0.15	0.27	0.42	0.69
10	0.09	0.17	0.30	0.46	0.76
12	0.11	0.20	0.35	0.55	0.90
14	0.12	0.23	0.40	0.63	1.04
16	0.14	0.26	0.46	0.72	1.17
18	0.16	0.29	0.51	0.80	1.31
20	0.17	0.32	0.57	0.89	1.45
25	0.21	0.39	0.70	1.10	1.80
30	0.26	0.47	0.84	1.31	2.15
35	0.30	0.54	0.97	1.52	2.49
40	0.34	0.62	1.11	1.73	2.84
45	0.38	0.70	1.24	1.95	3.19
50	0.42	0.77	1.38	2.16	3.53
55	0.46	0.85	1.51	2.37	3.88
60	0.50	0.92	1.65	2.58	4.23
65	0.54	1.00	1.78	2.79	4.57
70	0.58	1.07	1.92	3.01	4.92
75	0.63	1.15	2.05	3.22	
80	0.67	1.23	2.19	3.43	
85	0.71	1.30	2.32	3.64	
90	0.75	1.38	2.46	3.85	
95	0.79	1.45	2.59	4.07	
100	0.83	1.53	2.73	4.28	
105	0.87	1.60	2.86	4.49	
110	0.91	1.68	3.00	4.70	
115	0.95	1.75	3.13		
120	1.00	1.83	3.27		
125	1.04	1.91	3.40		
130	1.08	1.98	3.54		
135	1.12	2.06	3.67		
140	1.16	2.13	3.81		
145	1.20	2.21	3.94		
150	1.24	2.28	4.08		
155	1.28	2.36	4.21		
160	1.33	2.44	4.35		
165	1.37	2.51	4.48		
170	1.41	2.59	4.62		
175	1.45	2.66			
180	1.49	2.74			
185	1.53	2.81			
190	1.57	2.89			
195	1.61	2.97			
200	1.65	3.04			
120	1.82	3.34			
140	1.98	3.65			
260	2.15	3.95			
280	2.31	4.25			
300	2.48	4.55			
320	2.64	4.86			
240	2.81	5.16			
360	2.97				
380	3.14				
400	3.47				
420	3.63				
440	3.70				
460					

CAPACITY OF STEAM IN KG/HOUR AT SATURATED TEMPERATURE					
SET PRE- SSURE IN	ORIFICE LETTER DESIGNATION				
	C	D	E	F	G
1	25	48.8	88.7	141	232
2	35.4	66.7	120	191	314
3	43.7	82	148	234	384
4	50.8	95	171	270	444
5	58	107	192	302	496
6	62	117	211	331	544
7	68.8	127	228	358	587
8	73.6	136	243	383	628
9	78.2	14	258	406	666
10	82.5	152	272	428	702
12	90	167	299	469	769
14	97.8	180	323	507	831
16	104	193	345	542	889
18	111	204	366	575	943
20	117	216	386	606	994
25	133	243	434	678	1111
30	145	266	475	743	1217
35	157	288	513	803	1315
40	166	306	546	858	1406
45	176	324	579	910	1491
50	187	342	610	960	1572
55	194	359	641	1007	1649
60	203	375	669	1051	1722
65	211	390	697	1094	1793
70	219	405	723	1136	1860
75	36.5	67.9	122	192	
80	39	72.5	130.1	204.7	
85	41.4	77	138.2	217.4	
90	43.9	81.5	145.3	230.1	
95	46.4	86.1	154.4	242.9	
100	50.8	90.6	162.5	255.6	
105	51.3	95.2	170.6	268.3	
110	53.8	96.7	178.7	281	
115	56.2	104.2	186.8		
120	58.7	108.8	194.9		
125	61.2	113.3	203		
130	63.7	117.9	211.1		
135	66.1	122.4	219.2		
140	68.6	126.9	227.3		
145	71.1	131.5	235.4		
150	73.5	136	243.5		
155	76	140.6	251.6		
160	78.5	145.1	259.7		
165	80.9	149.6	267.8		
170	83.4	154.2			
			275.9		
175	85.9	158.7			
180	88.3	163.3			
185	90.8	167.8			
190	93.3	172.3			
195	95.8	176.9			
200	98.2	181.4			
220	108.1	199.6			
240	118	217.7			
260	127.9	235.9			
280	137.7	254.1			
300	147.6	272.2			
340	157.5	290.4			
360	167.4	308.5			
380	177.2				
400	527				
420	540				
440	552				
448	557				

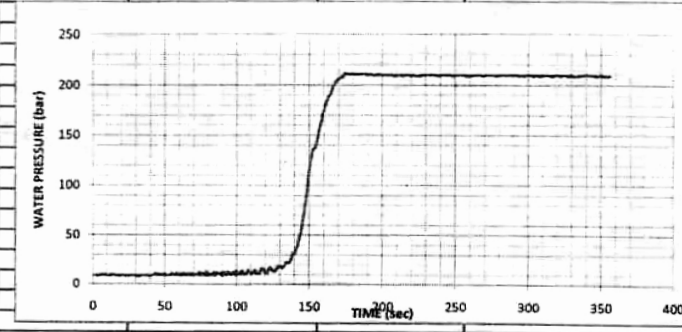
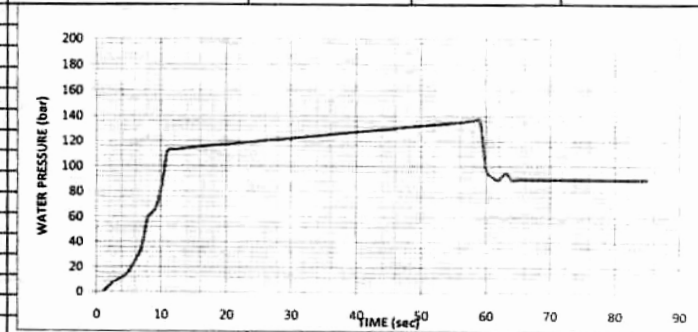
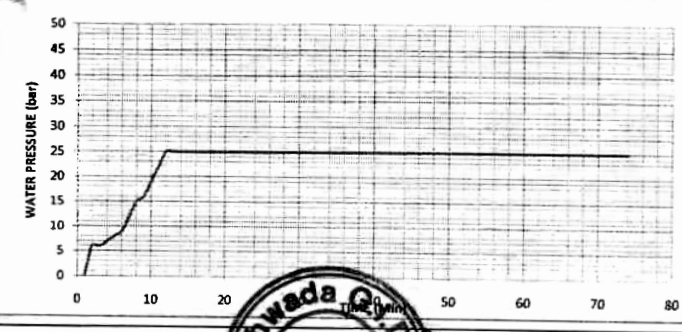
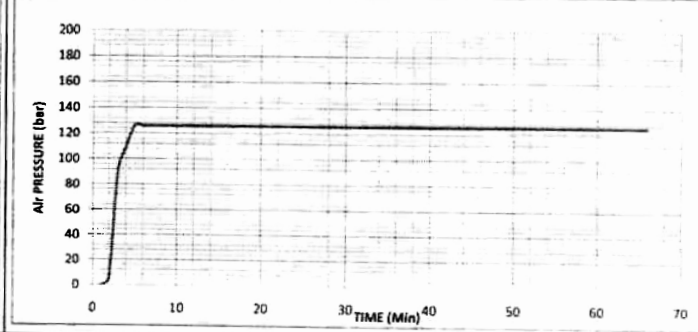
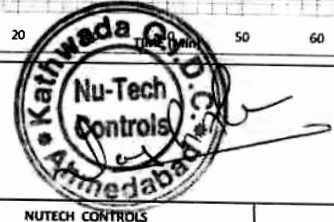
		<b>NU-TECH CONTROLS</b>	
AHMEDABAD, INDIA		Test Certificate	
CONFORMING to EN 10204:2004 Type 3:1			
Inspection Report No.: NC/IOEC/TBHG/01		Test Date:	21-Mar-2014
Client: IOEC		Description: 4" x 6" PILOT OPERATED SAFETY VALVE	
P.O. No.:		Work Order No.:	
P.O. Date:		Work Order Date.:	
<b>Product Description</b>			
Valve Type :	Pilot Operated	Inlet Size :	4
Test Media:	AIR	Outlet Size:	6
Heat No.:	170	Serial No.:	P46-63
		Inlet Class:	2500
		Outlet Class:	300
		End Connection:	RTJ X RF
<b>Standards/Specification</b>			
Design/Mfg. Standard:- API/ BS En ISO 17292/BS 5351		Testing Standard:- API 598	
Face to Face Standard:- ASME B 16.10		End Connection:- ANSI B 16.5	
<b>Material of Construction</b>			
BODY MOC	ASTM A494 Gr.CW6MC		
SEAL MOC	ASTM A494 Gr.CW6MC		
<b>Pressure Testing</b>			
ACTUAL POP-UP PRESSURE		137	
<b>INLET PRESSURE @ BACK PRESSURE</b>			
Test Type	Pressure (Bar)	Holding Time (Sec)	Test Type
Hydro Shell Test	210	180	Air shell Leak Test
Performance Test	139		Seat Leak Test
			Pressure (Bar)
			25
			125
			Holding Time (Sec)
			3600
			3600
<b>Hydro Shell Test Graph</b>		<b>Performance Test Graph</b>	
			
<b>Air Shell Leak Test Graph</b>		<b>Seat Leak Test Graph</b>	
			
			

<b>SGS</b>	WITNESSED
	REVIEWED
Date & Signature: <i>26-03-2014</i> Nilant Khopkar SGS INDIA PVT. LTD., AHMEDABAD	
The SGS stamp and signature is for witnessing / observation purposes only and is subject to the provisions of the SGS General Conditions of Services particularly article 2(d), available at <a href="http://sgs.com/terms_and_conditions">http://sgs.com/terms_and_conditions</a> .	

Understanding the true meaning of Precision





myway +91 79 27544396

**INDUSTRIAL, AUTOMATION VALVES AND HIGH PRESSURE SOLUTIONS**



156, Tribhuvan Industrial Estate, B/h. Kathwada GIDC,  
Ahmedabad-382430, Gujarat, India. Ph. : +91 79 22133122 / 23.  
Email : [sales@nutechvalves.com](mailto:sales@nutechvalves.com) | [sales@nutechcontrols.com](mailto:sales@nutechcontrols.com)  
Website : [www.nutechvalves.com](http://www.nutechvalves.com) | [www.nutechcontrols.com](http://www.nutechcontrols.com)